



PUBLIC HEARING

Agenda Item # 9

AGENDA REPORT SUMMARY

Meeting Date: August 24, 2021

Subject: Zoning Text Amendment ZTA 20-0003 to repeal and replace the design control sections of the Los Altos Municipal Code to codify objective zoning standards pursuant to recent changes to state law.

Prepared by: Guido F. Persicone, Planning Services Manager
Jon Biggs, Community Development Director

Reviewed by: Gabriel Engeland, City Manager

Attachments:

1. Objective Standards Ordinance
2. Objective Design Standards - clean version
3. Project Comments
4. Response to Comments

Initiated by:
City Council Priority

Previous Council Consideration:
February 23, 2021, March 16, 2021, and July 13, 2021,

Fiscal Impact:
This meeting does not have a fiscal impact on the City because the consultant contract was previously approved by the Council on March 17, 2020 and was amended on May 11, 2021.

Environmental Review:
The proposed Ordinance relates to organizational or administrative activities of governments that will not result in direct or indirect physical changes in the environment and therefore is exempt from California Environmental Quality Act ("CEQA") pursuant to CEQA Guidelines Section 15061(b)(3), which states the general rule that CEQA applies only to projects which have the potential for causing a significant effect on the environment." The Ordinance has no potential to result in a direct, or reasonably foreseeable, indirect impact on the environment, and it also adheres to CEQA Guidelines Section 15308 (Actions by Regulatory Agencies for the Protection of the Environment). The proposed Objective Standards will also preserve the scenic quality of the City of Los Altos by establishing enforceable development standards and design guidelines that are intended to protect the existing community character.



Subject: Objective Standards -Zoning Text Amendment ZTA 20-003

Policy Question(s) for City Council Consideration:

- Do the proposed Objective Standards provide adequate and appropriate direction that can be relied on by the community to guide change in Los Altos?

Summary:

This is a public hearing on the proposed objective standards, which allows the City Council an opportunity to continue its review of these new regulations.

Staff Recommendation:

1-Introduce and waive further reading of the draft ordinance as amended by the City Council at the February 23, 2021, March 16, 2021, July 13, 2021 meetings leading to adoption of the Objective Standards (Attachment 1- Objective Standards Ordinance)

2-Introduce and waive further reading of the draft ordinance as amended by the City Council at the February 23, 2021, March 16, 2021, July 13, 2021 meetings leading to adoption of the Objective Standards (Attachment 1-Objective Standards Ordinance) and refer the amendments back to the Planning Commission for further study.

3-Introduce and waive further reading of the January 2021 Planning Commission recommended version of the draft ordinance.

4-Further amend the ordinance but send it back to the Planning Commission for additional review and study.

Purpose

Objective zoning standards are intended to guide future multi-family development in Los Altos.

Background

On January 28, 2020, the City Council adopted a resolution directing City staff to accept Senate Bill 2 (SB 2) grant funds from the State of California in order to prepare objective zoning standards. Following the conclusion of this meeting, a Request for Proposals (RFP) was sent out via the City website, to all interested parties and consulting firms. After release of the RFP a Pre-Bid Conference call was organized by City staff. Five consulting firms participated in this pre bid meeting allowing them to ask questions and to receive clear direction from City staff regarding the information needed in the RFP submittal package. February 28, 2020 was the deadline to submit a proposal to Los Altos. On this date, the City received one proposal from Lisa Wise Consulting (LWC) in conjunction with Opticos Design.

On March 17, 2020, the City Council authorized a contract with the consultant team (Lisa Wise Consultant in conjunction with Opticos Design) to prepare objective zoning standards to help guide



Subject: Objective Standards -Zoning Text Amendment ZTA 20-003

future development in the City in light of recent changes to state law.¹ While the contract was approved by the City Council, a subcommittee was formed of Councilmembers Bruins and Pepper to iron out the project schedule and the final language of the agreement. After two meetings with the consultant team in April, the contract was ready for signature and fully executed by the City on April 30, 2020.

In April/May 2020 the consultant team conducted a thorough background assessment of relevant multifamily and residential mixed-use objective design standards including but not limited to the General Plan, the Housing Element, the Zoning Code and the Downtown Design Guidelines among other relevant documents and reports.

On June 10th and 11th of 2020, approximately 30 interviews were conducted with key project stakeholders including local architects, city staff, community members, downtown business owners, and appointed and elected officials.

On June 30, 2020, a joint Planning Commission and City Council meeting occurred to review the project. The purpose of the June 30, 2020 meeting was to provide the City Council the broad themes that have been garnered from a review of the existing Los Altos codes and from comments/feedback provided by the stakeholders.

On July 14th, 15th, 16th, 2020, based on feedback from the City Council, additional outreach was done to capture all stakeholder voices for this project. Eight additional stakeholders were interviewed by the consultants.

On September 9, 2020, a joint meeting of the Planning Commission and City Council occurred to discuss the Draft Objective Standards. The focus of this meeting was to ensure that the Annotated Framework was consistent with Council direction.

On October 27, 2020, a joint meeting of the Planning Commission and City Council occurred. The focus of this meeting was to further clarify City Council direction prior to the Planning Commission reviewing the document during subsequent public hearings.

On November 5, 2020, the Planning Commission held its first public hearing on the objective standards and following a lengthy discussion on all elements of the draft code, directed staff and the consultant team to develop some modifications based on its feedback and return with the revisions.

¹ See SB 330, SB 35, AB 1485 and AB 881 for modifications to State law that require more clear zoning standards moving forward.



Subject: Objective Standards -Zoning Text Amendment ZTA 20-003

On December 3, 2020, the second Planning Commission public hearing of the objective standards was held. The Commissioners conducted another thorough review of the draft regulations and following its review developed some specific adjustments they felt would enhance the overall effectiveness of the standards.

On January 21, 2021 the third Planning Commission public hearing occurred. After a review of the modifications, the Commission recommended approval to the Council of the objective zoning standards, subject to a few other adjustments.

At its Study Session on February 23, 2021, the City Council reviewed a draft of the Objective Standards (Attachment 2-Objective Design Standards - clean version) and provided the following direction to staff on the next steps in the review of these regulations:

1. Meet with each Councilmember individually and answer questions and provide clarifications about the Objective Standards
2. Collect and distribute to the full City Council edits or written requests of individual Councilmembers for modifications or topics to be included in the Objective Standard.
3. Develop a list of additional resources or information that will assist the City Council as it reviews the Objective Standards.

On March 16, 2021 after staff had an opportunity to meet one-on-one with each of the Councilmembers and address questions as well as listen to recommendations and suggestions, the objective standards were brought back, so that all City Council members could collectively see and share in the input that had been provided and allow it to provide further direction to the consultant team and staff before the draft ordinance was returned to the City Council at a public hearing.

On July 13, 2021, the Council again considered a draft of the objective standards and its actions as a result of this review is explained and addressed below.

Discussion

Following its deliberation, the City Council referred the ordinance back to staff and the consultant team with direction that any edits or suggested modifications to the ordinance by members of the City Council or members of the public be provided to staff as soon as possible so that it could edit the draft ordinance as appropriate for return to the City Council and further consideration.

Staff has received edits and comments from Mayor Fligor, Vice Mayor Enander, and City Councilmember Lee-Eng as well as comments from some members of the public – these



Subject: Objective Standards -Zoning Text Amendment ZTA 20-003

are included with this agenda report under Attachment 3 (Project Comments). In Attachment 4 (Response to Comments), the City Council will find a list of all the comments with a reply to each. All the comments have been reviewed and, where appropriate, the Draft Objective Standards attached with this agenda report, Attachment 2 (Objective Standards-clean version), have been modified to incorporate the comment. Some of the comments require a broader consideration by the full City Council and the replies in Attachment 4 (Response to Comment) reflect this.

Conclusion

The City Council is considering a broadly sweeping update to the City’s zoning code that provides “objective standards” against which future projects will be evaluated. These objective standards are intended to provide clear and measurable site development standards against which applicants, staff, decision makers and the community can evaluate a project. These standards are being developed in response to recent legislation at the State level that has increasingly removed a city’s ability to exercise discretion in the review of a project, either a multifamily housing project or a mixed-use project.

As defined by Government Code 65400, objective zoning standards and objective design review standards mean standards that involve no personal or subjective judgment by a public official and are uniformly verifiable by reference to an external and uniform benchmark or criterion available and knowable by both the development applicant or proponent and the public official prior to submittal.

Objective Standards have been developed for each zone district in Los Altos that allows, either as a permitted or conditionally permitted use, multi-family or mixed-use projects. In addition to the typical site development standards, such as setback, height limit, and coverage requirements, the City Council will find standards that will be applicable to the design and form of buildings. These have been developed using best practice standards and the expertise of the Consultant team, which has developed objective standards for many other communities in California, along with the input of the Planning Commission and City Council members.

The purpose of the August 24, 2021, meeting is to allow City Council members to review the revised document in light of the input provided by the full City Council in July of this year.

Options

- 1) Introduce and waive further reading of the draft ordinance as amended by the City Council at the February 23, 2021, March 16, 2021, July 13, 2021 meetings leading to adoption of the Objective Standards (Attachment 1- Objective Standards Ordinance).



Subject: Objective Standards -Zoning Text Amendment ZTA 20-003

Advantages: Allows the project to continue towards adoption at a meeting in the near term

Disadvantages: There is no disadvantage to adopting regulations that are compliant with state law.

- 2) Introduce and waive further reading of the draft ordinance as amended by the City Council at the February 23, 2021, March 16, 2021, July 13, 2021 meetings leading to adoption of the Objective Standards (Attachment 1-Objective Standards Ordinance) and refer the amendments back to the Planning Commission for further study

Advantages: Would provide a venue for the Planning Commission to take another look at the Objective Standards and develop recommendations that enhance/improve the adopted Objective Standards that could be brought forward as amendments at a later date for City Council consideration.

Disadvantages: If the Planning Commission made recommendations that are different than what is adopted it may provide some uncertainty for those submitting development applications submitted based on adopted Objective Standards.

- 3) Introduce and waive further reading of the January 2021 Planning Commission recommended version of the Draft Ordinance.

Advantages: Introduces the Objective Standards regulations and allows them to proceed towards adoption.

Disadvantages: There is no disadvantage to adopting regulations that are compliant with state law.

- 4) Further amend the ordinance but send back to the Planning Commission for additional review and study.

Advantages: Will allow time for additional information to be collected and the ordinance to be modified to reflect the input of the Planning Commission

Disadvantages: Delays the adoption of these regulations.

The staff recommends Option 1.

ORDINANCE NO. 2021-478

**AN ORDINANCE OF THE CITY COUNCIL OF THE CITY OF LOS ALTOS
AMENDING TITLE 14 (ZONING) BY CREATING OBJECTIVE ZONING
STANDARDS FOR RESIDENTIAL DEVELOPMENT**

WHEREAS, the Housing Accountability Act, Government Code Section 65589.5, limits a public agency’s ability to deny approval of a housing development project or to approve the project at a lower density if the project complies with any and all objective general plan, zoning, design, and subdivision standards applicable to the project; and

WHEREAS, on January 1, 2018, Senate Bill 35, intended to help address California’s housing shortage, went into effect requiring streamlined and ministerial review process for multifamily and mixed-use housing projects meeting specific qualifications; and

WHEREAS, on January 1, 2020, Senate Bill 330 went into effect encouraging the use of objective design standards and discouraging the adoption of new subjective design standards; and

WHEREAS, as defined by the Housing Accountability Act and Senate Bill 35 (Government Code Sections 65589.5 and 65913.4), objective zoning standards and objective design review standards mean standards that involve no personal or subjective judgment by a public official and are uniformly verifiable by reference to an external and uniform benchmark or criterion available and knowable by both the development applicant or proponent and the public official prior to submittal; and

WHEREAS, on November 5, 2020, December 3, 2020, and January 21, 2021, the Planning Commission held a duly noticed public hearings on Zoning Code Text Amendment (ZTA 20-003); and

WHEREAS, on January 21, 2021, the Planning Commission recommended approval of the proposed zoning text amendment Zoning Text Amendment (ZTA 20-003) to the City Council; and

WHEREAS, on February 23, 2021, March 16, 2021, and July 13, 2021, August 24, 2021, the City Council reviewed Zoning Text Amendments (ZTA 20-0003); and

WHEREAS, this Ordinance implements Policy 1.4 and Policy 2.4 of the of the City’s 2015-2023 Housing Element by evaluating the design review process and by ensuring the orderly development of multifamily housing within Los Altos; and

WHEREAS, based on all the evidence presented in the administrative record, including but not limited to the staff reports for the proposed Objective Standards, the proposed Ordinance relates to organizational or administrative activities of governments that will not result in direct or indirect physical changes in the environment, and therefore is exempt from California Environmental Quality Act (“CEQA”) pursuant to CEQA Guidelines Section 15061(b)(3), which states the general rule that CEQA applies only to projects which have the potential for causing a significant effect on the environment as the Ordinance has no potential to result in

a direct, or reasonably foreseeable, indirect impact on the environment; and pursuant to CEQA Guidelines Section 15308 (Actions by Regulatory Agencies for the Protection of the Environment), in that the proposed Objective Standards will preserve the scenic quality of the City of Los Altos by establishing enforceable development standards and design guidelines that are intended to protect the existing community character.

WHEREAS, the streamlining of multifamily housing development projects will assist the City of Los Altos in achieving State and regional goals for the construction of new affordable units as defined in the Regional Housing Needs Allocation (RHNA) process;

NOW THEREFORE, the City Council of the City of Los Altos does hereby ordain as follows:

SECTION 1. AMENDMENT OF CODE: Title 14 of the Los Altos Municipal Code is hereby amended and replaced with the new standards and shall read as follows:

The following definitions shall be added to 14.02.070 (Definitions) of the Los Altos Municipal Code:

“Board-formed concrete” means concrete that has textured patterns on its finished surfaces that retain the wood grain of boards or molds used to form the wet concrete.

“Chamfered corner” means a building corner which is cut back at a 45-degree diagonal from the primary façade to provide a corner surface at least 8 feet in length

“Façade” means the exterior wall on all sides of the building.

“Façade” means the exterior wall on any side of a building. “Lined” parking refers to a building configuration where residential, commercial, or office uses are located between a street-facing property line and above-ground parking levels. Also referred to as a “wrapped” building

“Lined” refers to parking located behind non-residential uses.

Section 14.66.180 (Maintenance of landscape areas) shall be amended to read as follows:

14.66.180 - Maintenance of landscaped areas- A landscaped strip or other landscaped area provided in compliance with district regulations or as a ~~condition approval of a use permit~~ shall be planted with fast growing materials suitable for screening or ornamenting the site, whichever is appropriate, and plant materials shall be replaced as needed to screen or ornament the site. Landscaped strips and other landscaped areas shall be watered, weeded, pruned, fertilized, sprayed, or otherwise maintained as deemed necessary by the building inspector.

R3-4.5-14.16.100- Design Controls-repealed and replaced with Objective Design Standards, identified as Exhibit A to this ordinance, which are incorporated herein by this reference.

R3-5-14.18.120-Design Controls-repealed and replaced with Objective Design Standards, identified as Exhibit A to this ordinance, which are incorporated herein by this reference.

R3-3-14.20.120-Design Controls-repealed and replaced with Objective Design Standards, identified as Exhibit A to this ordinance, which are incorporated herein by this reference.

R3-1.8-14.22.110-Design Controls-repealed and replaced with Objective Design Standards, identified as Exhibit A to this ordinance, which are incorporated herein by this reference.

R3-14.24.110-Design Controls-repealed and replaced with Objective Design Standards, identified as Exhibit A to this ordinance, which are incorporated herein by this reference.

CN-14.40-150-Design Controls-repealed and replaced with Objective Design Standards, identified as Exhibit A to this ordinance, which are incorporated herein by this reference.

CD-14.44.130-Design Controls-repealed and replaced with Objective Design Standards, identified as Exhibit A to this ordinance, which are incorporated herein by this reference.

CRS-14.48.130-Design Controls- repealed and replaced with Objective Design Standards, identified as Exhibit A to this ordinance, which are incorporated herein by this reference.

CT-14.50.170-Design Controls- repealed and replaced with Objective Design Standards, identified as Exhibit A to this ordinance, which are incorporated herein by this reference.

CD/R3-14.52.110-Design Controls-repealed and replaced with Objective Design Standards, identified as Exhibit A to this ordinance, which are incorporated herein by this reference.

CRS/OAD-14.54.130-Design Controls-repealed and replaced with Objective Design Standards, identified as Exhibit A to this ordinance, which are incorporated herein by this reference.

SECTION 2. 14.66.275 and 14.66.280 ADDED: The Los Altos Municipal Code is hereby amended to add the following new subsections:

14.66.275-Entrance Type Standards-as referenced in Exhibit A (Objective Design Standards)

14.66.280-Design Standards to All Multi-Family Zones and Commercial Zones that Support Residential Mixed-Use Development as referenced in Exhibit A (Objective Design Standards).

SECTION 3. SEVERABILITY. If any section, subsection, sentence, clause or phrase of this code is for any reason held to be invalid or unconstitutional, such decision shall not affect the validity of the remaining portions of this code.

SECTION 4. CEQA. The City Council finds the adoption of this ordinance to be statutorily exempt from the requirements of the California Environmental Quality Act (CEQA) pursuant to Sections 15061(b)(3) and 15308, of the CEQA Guidelines.

SECTION 5. PUBLICATION. This ordinance shall be published as provided in Government Code section 36933. Within 15 days of the passage of this ordinance, the City Clerk shall cause the full text of the ordinance, with the names of those City Council members voting for and against the ordinance, to be published in an adjudicated newspaper. In lieu of

publishing the full text of the ordinance, the City Clerk, if so directed by the City Attorney and within 15 days, shall cause a summary of the ordinance, prepared by the City Attorney and with the names of the City Council members voting for and against the ordinance, to be published in an adjudicated newspaper, and shall post in the office of the City Clerk a certified copy of the full text of the ordinance, along with the names of those City Council members voting for and against the ordinance. The publication of a summary of the ordinance in lieu of the full text of the ordinance is authorized only where the requirements of Government Code Section 36933(c)(1) are met.

SECTION 6. EFFECTIVE DATE. This ordinance shall be effective upon the commencement of the thirty-first day following the adoption date.

The foregoing ordinance was duly and properly introduced at a regular meeting of the City Council of the City of Los Altos held on _____, 2021 and was thereafter, at a regular meeting held on _____, 2021 passed and adopted by the following vote:

- AYES:
- NOES:
- ABSENT:
- ABSTAIN:

Neysa Fligor Mayor

ATTEST

Andrea Chelemengos MMC, City Clerk

Exhibit A-City of Los Altos Objective Design Standards



City of Los Altos Objective Design Standards

Hearing Draft

August 2021

Prepared for:

City of Los Altos
1 N. San Antonio Road
Los Altos, CA 94022

Prepared by:

Lisa Wise Consulting, Inc.
870 Market Street, Suite 977
San Francisco, CA 94102

Table of Contents

Revised 14.40.150 Design Control (CN)3

Revised 14.44.130 Design Control (CD)15

Revised 14.48.130 Design Control (CRS).....28

Revised 14.50.170 Design Control (CT)40

Revised 14.52.110 Design Control (CD/R3).....53

Revised 14.54.130 Design Control (CRS/OAD).....67

Revised 14.16.100 Design Control (R3-4.5).....80

Revised 14.18.120 Design Control (R3-5).....83

Revised 14.20.120 Design Control (R3-3).....88

Revised 14.22.110 Design Control (R3-1.8).....92

Revised 14.24.110 Design Control (R3-1).....96

New Section 14.66.275 Entrance Type Standards.....103

New Section 14.66.280 Design Standards Applicable to All Multi-Family and Residential Mixed-Use Development107

Content to be Added to 14.02.070 Definitions113

This page intentionally left blank.

Revised 14.40.150 Design Control (CN)

A. Building Placement. A minimum 75 percent of ground-floor building frontages facing El Camino Real must be built at the minimum setback line. This standard applies to the building frontage only (exclusive of side setbacks).

B. Building Massing and Articulation.

1. ***Upper-story Step-backs, Front and Street Side***

- a. Along all frontages except El Camino Real, the third story must be either stepped back a minimum 5 feet from the ground floor façade or embedded in a sloped roof form such as a mansard roof or a hipped and/or gabled roof with dormers, as allowed by standards in Section 14.40.150.B.7.
- b. For buildings over three stories along all frontages except El Camino Real, the uppermost story must be embedded in a sloped roof form.

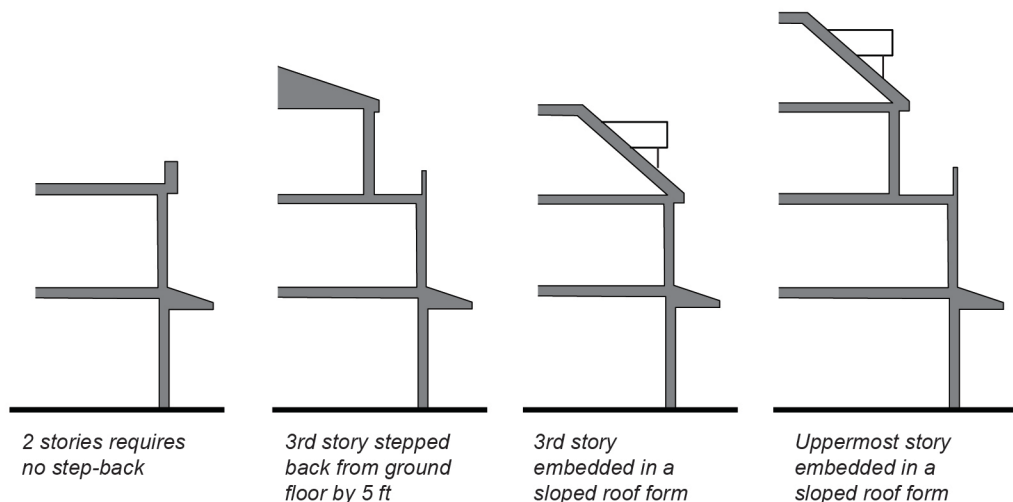

2. ***Upper Story Step-backs, Side Interior and Rear where Abutting an R-1 District.***

- a. The third story must be either stepped back a minimum 10 feet from ground floor façade or embedded in a sloped roof form.
- b. For buildings over three stories, the uppermost story must be embedded in a sloped roof form.

3. ***Vertical Articulation.***

- a. When a building façade exceeds 75 feet in length along a right of way, it must be separated into primary façade bays no greater than 50 feet and secondary façade bays defined by a recess a minimum of 3 feet deep.
- b. A minimum one entrance shall be provided per primary façade bay.
- c. The eave/roof of a secondary façade bay shall be no higher than the corresponding elements of the primary façade bay.

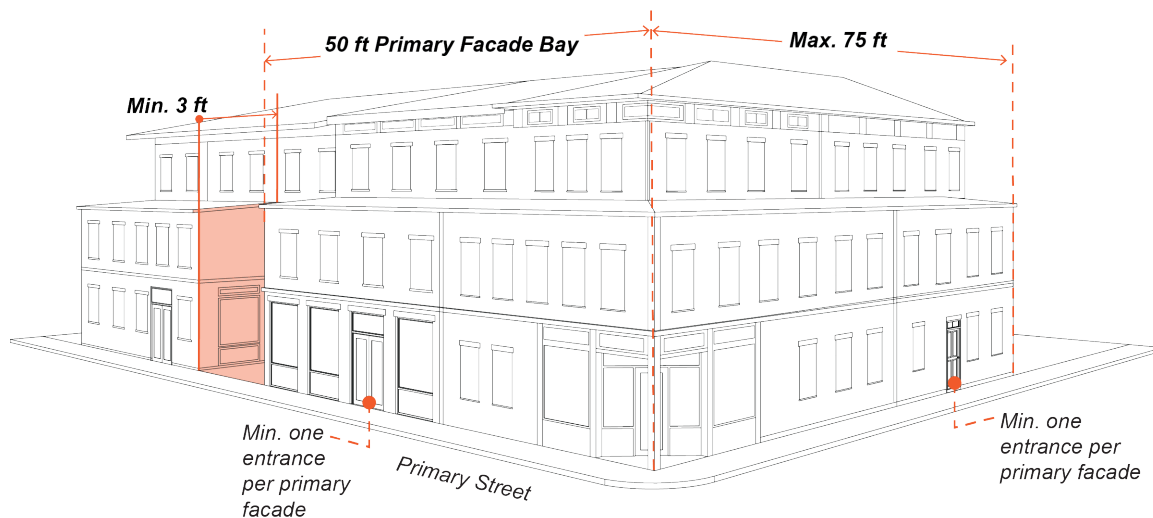

4. **Horizontal Articulation.** New facades and façade modifications along a street or civic space shall be designed to visually express a base, middle, and top.
- a. One or more of the following patterns shall be used to define the base:
 - i. Watertable: Base material extends from grade to between 8 and 54 inches above grade.
 - ii. Podium: The base material encompasses the lowest story (or stories) of the building, with or without mezzanine(s), and terminates in a sill, string course, or cornice at its upper bound (multi-story buildings only).
 - iii. Watertable + Cornice/String Course: A watertable using the base material is combined with a cornice or string course at the lowest story's upper bound, including any mezzanine (multi-story buildings only).
 - b. The top of each building mass/bay shall be defined by elements spanning the full length of the façade of the mass/bay. Such elements may include a cornice, eave and/or gable(s), or other elements listed under Section 17.40.150.B.7. These elements shall be consistent with the overall architectural style of the building mass/bay.

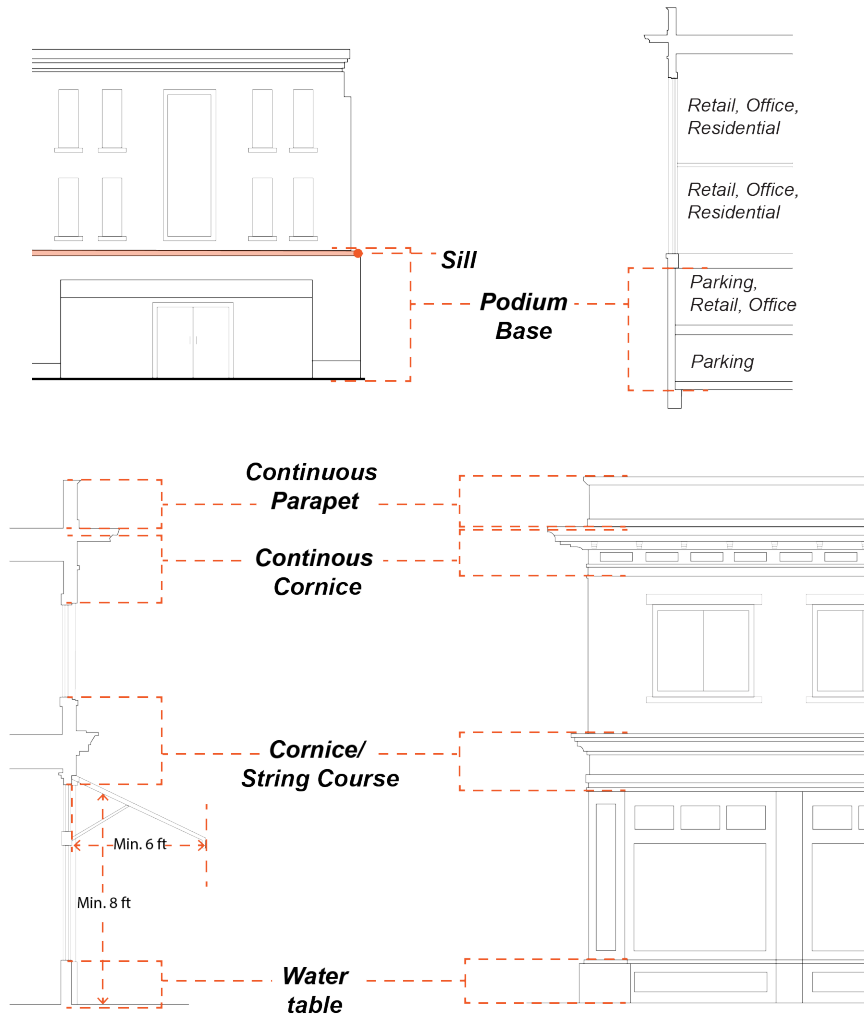

5. **Adjacencies.**

a. *Facades Adjacent to an R-1 District.*

- i. Building façade planes abutting an R-1 district may not exceed 48 feet in width.
- ii. When a building façade abutting an R-1 district exceeds 48 feet in width, it must be separated into façade bays no greater than 48 feet by a recess 10 feet wide and 15 feet deep.
- iii. Balconies, roof decks and other habitable outdoor space is not allowed on upper-story facades abutting R-1 zones.
- iv. Sliding glass doors, French doors, and floor-to-ceiling windows are not allowed on upper-story facades abutting R-1 zones.

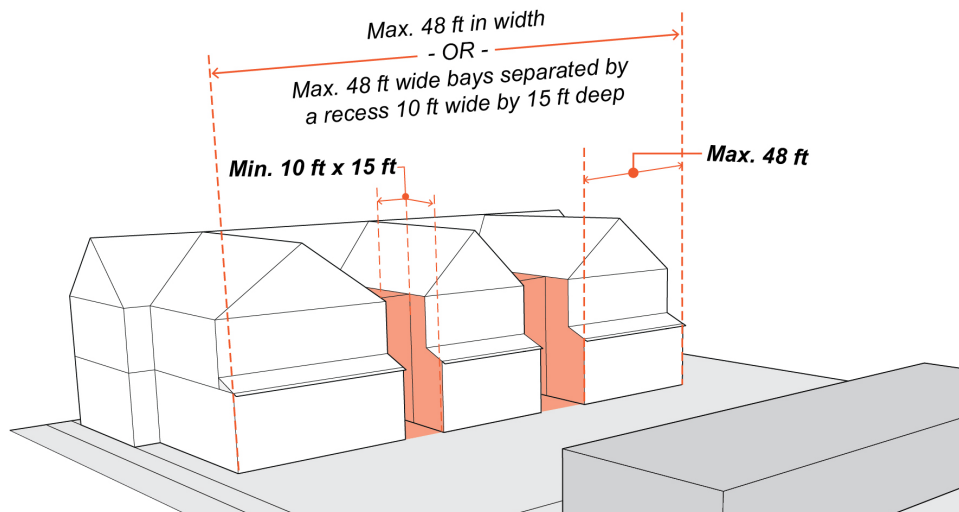

b. *Storefront Facades Adjacent to Storefront Facades.*

- i. The height of a storefront shall not differ from the height of any adjacent storefront by more than 2 feet.
- ii. The height of ground story shall not differ from height of any adjacent ground story by more than 2 feet.
- iii. Storefronts may transition in height using a module of 25 feet in length along a right-of-way.

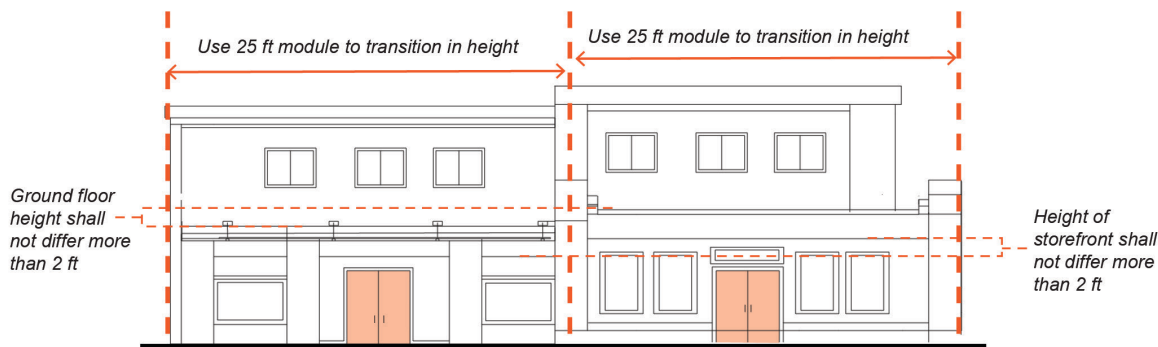

c. *Compatibility with Adjacent Shorter Buildings with Height Difference of One Story or More.* When adjacent to an existing shorter building with a height difference of one story or more, a proposed building must utilize two or more of the following strategies:

- i. Incorporate the uppermost floor into the roof form
- ii. Break the mass of the building into smaller modules through changes in wall plane, setbacks, and/or height
- iii. Match window heights and/or proportions
- iv. Relate roof cornices and moldings at floor lines

6. **Privacy and Line of Sight.**

- a. Primary living spaces and balconies located along a side setback shall orient principal windows and balconies toward the front and rear of the building.
- b. Where windows are within 10 feet of and oriented toward an interior side setback, glazing shall either be a minimum 30-degree angle measured perpendicular to the adjacent side setback line, have minimum sill height of 42 inches, or be opaque.
- c. The maximum sill height for an ingress/egress window is 44 inches from finished floor.

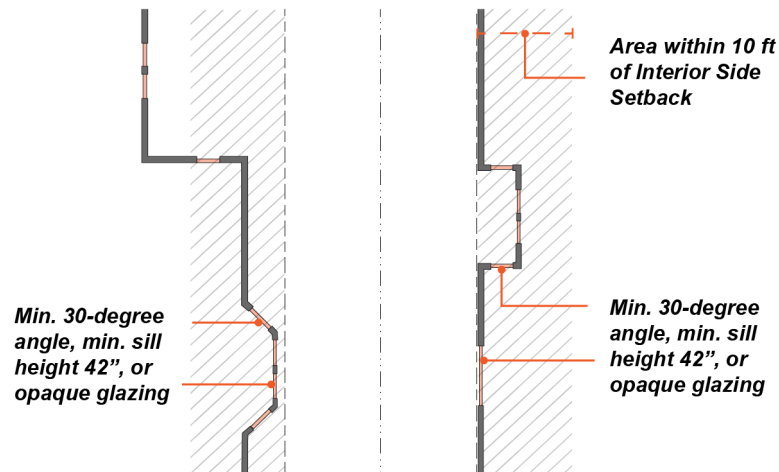

7. **Roofline and Roof Design.**

- a. Roof designs shall be limited to:
 - i. Hipped
 - ii. Gable
 - iii. Shed
 - iv. Dormer
 - v. Parapet
 - (a) Not allowed on frontages facing Fremont Avenue.
 - (b) When used on the first or second floor, a parapet longer than 25 feet in length must include at least one but not more than two of the following design elements to break up the length of the parapet:
 - (1) Steps
 - (2) Curves
 - (3) Angled surfaces

- (c) The length of a parapet segment on the third floor and above may not exceed 25 feet.
- b. When the top story is stepped back and embedded in a sloped roof form such as a mansard roof or a hipped and/or gabled roof with dormers, the floor below must (and other floors may) be stepped back to meet the slope of the top story.

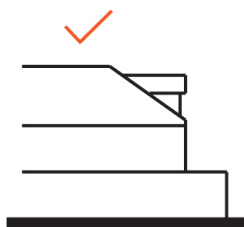

Acceptable:
One story below the story embedded in a sloped roof is also stepped-back .

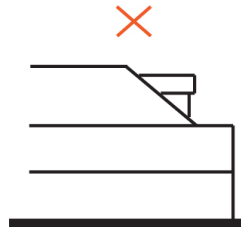

Not acceptable:
Top story embedded in a sloped roof is the only story stepped back.

- c. Building façades facing an R-1 district must have a hipped or gable roof and may incorporate dormers.
- d. Roofline/parapet at corners shall not exceed roofline/parapet of adjacent wallplanes by more than 24 inches.

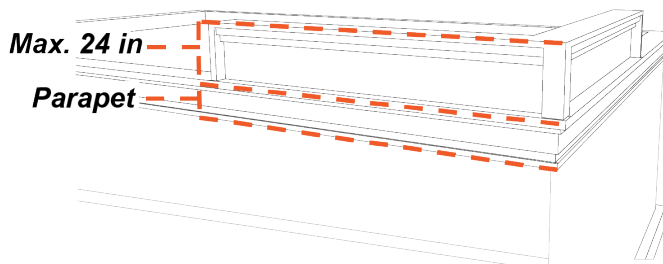

C. Building Design.

1. Façade Design.

- a. Building facades shall be arranged in an orderly composition of bays, defined by vertically aligned openings alternating horizontally with solid walls or columns. The pattern shall be visually expressed through the spacing of openings, recesses, eaves, inset panels, cornices, overhangs, trellises, exposed rafters, columns, or bay windows.
- b. The pattern may be shared between the ground floor and upper stories provided the ground floor exhibits enhanced detail or modulation.
- c. Residential facades shall incorporate at least one element that signals habitation, such as bay windows, or balconies.
- d. Non-glazed wall areas (blank walls) at the ground level must be enhanced with architectural details, landscaping, and/or landscaped trellises or lattices.

2. Pedestrian-Scaled Entrances.

- a. Building entrances must incorporate at least one of the following entry features. See Section 14.66.275 (Entrance Type Standards) for design standards applicable to each entrance type listed.
 - i. Stoop
 - ii. Dooryard
 - iii. Shopfront
 - (a) Shopfronts more than 25 feet in width must incorporate variations in bulkhead, awnings, materials and/or color to visually articulate the shopfront into modules not to exceed 25 continuous feet.
 - iv. Gallery
 - v. Arcade
 - vi. Forecourt
 - (a) Forecourts must feature at least one entry to a shop and/or second floor use.
 - (b) Forecourts for buildings more than 70 feet in length along a right-of-way must have a minimum width and depth of 15 feet from front façade. Width of forecourt shall be equal to or greater than depth.
 - (c) The size of the forecourt must be appropriate relative to the size of the building. The maximum ratio of building height to forecourt is 2:1 (height < 2 x width).
 - (d) Forecourt must be enclosed on at least three sides by buildings.
 - (e) Forecourt must remain open to the sky (arbors and trellises are allowed).

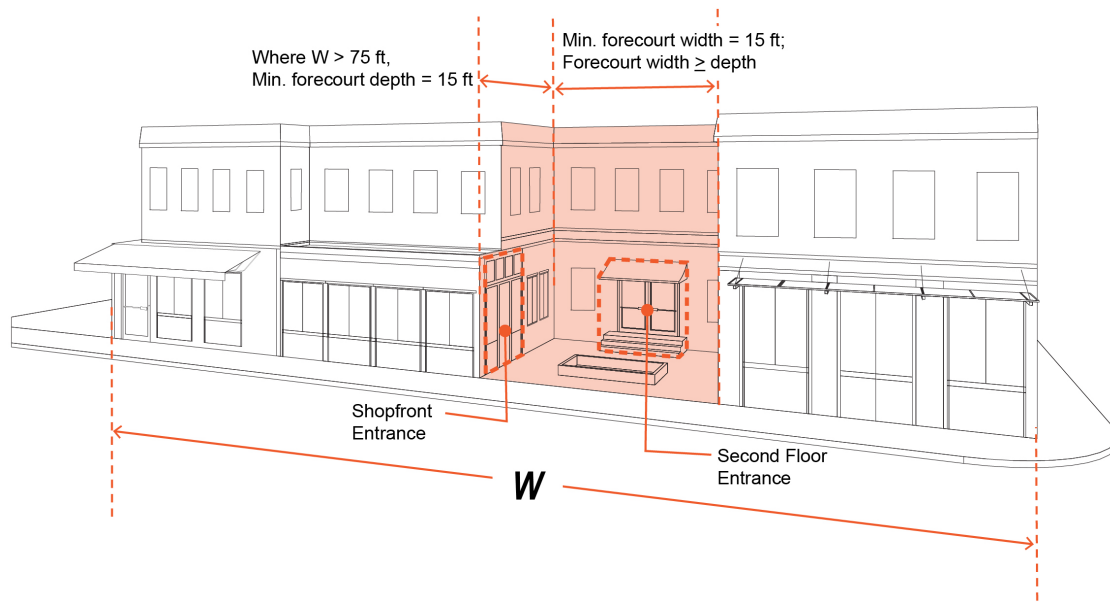

- b. *Primary Entrance Location(s).* The building entrance shall be located along the primary right-of-way.
- c. *Individual Entries.* Ground floor residential units facing a street must provide individual entries along the street frontage.
- d. *Corner Entrances.* Chamfered corners must incorporate a building entrance. Any required entrances may be provided on the corner of the building assuming one of the intersecting sides is a primary frontage.
- e. *Street-facing Entries to Upper Floors.* Street-facing entries to upper floors shall be equal in quality and detail to storefronts. This standard may be satisfied through two or more of the following:
 - i. Dedicated awning, canopy, or other roof element
 - ii. Stairs with a single color applied to treads and a contrasting color or pattern applied to risers.
 - iii. Dedicated light fixture(s)
 - iv. Decorative street address numbers or tiles
 - v. Plaque signs for upper-floor business tenants
- f. *Entry Protection.* Primary street-facing entrances shall be protected by a recess in the building frontage at least 3 feet deep or by a projection extending outward at least 3 feet measured horizontally from the entrance, and wide enough to clear the building entryway on both sides.
 - i. Protection may be coterminous with an accent element.
 - ii. Protection may take the form of an extended eave, overhang, awning, door canopy, gallery, arcade frontage, or other element that provides shade and shelter from the elements.

- i. The lowest edge of a projecting awning or door canopy shall have a vertical clearance of no more than 8 feet.
- ii. Recessed entries shall differentiate pavement within the recess through the use of a dedicated paving material or pattern.

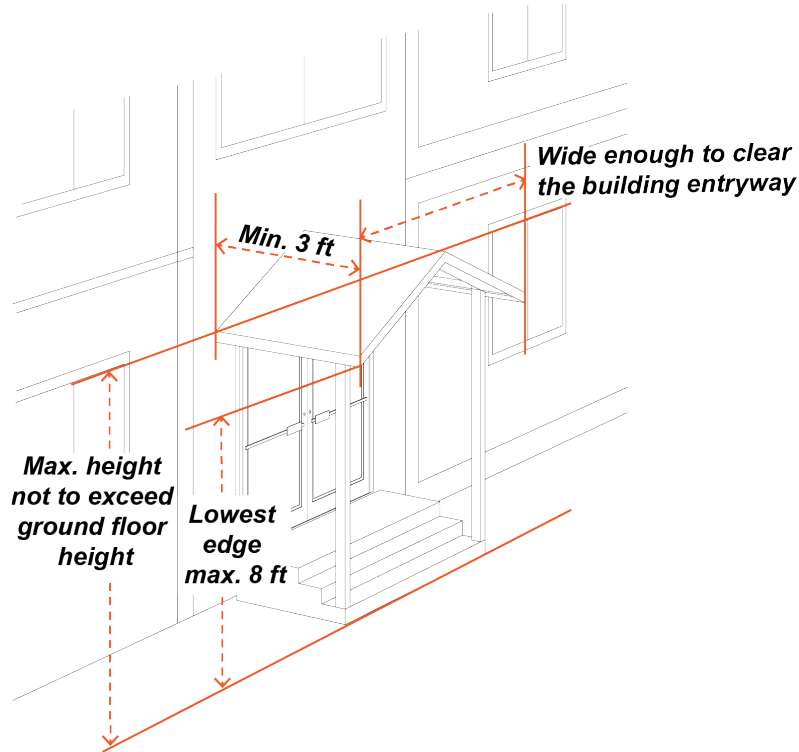

- g. Accent elements demarcating building frontage, entrance, and common open space areas shall not exceed the height of the ground floor story. Roof elements are exempted.

3. **Ground Floor Floor-to-Ceiling Height.**

- a. Minimum 24 inches taller than typical upper floor floor-to-ceiling height where ground floor is non-residential.
- b. Minimum 12 inches taller than typical upper floor floor-to-ceiling height where ground floor is residential

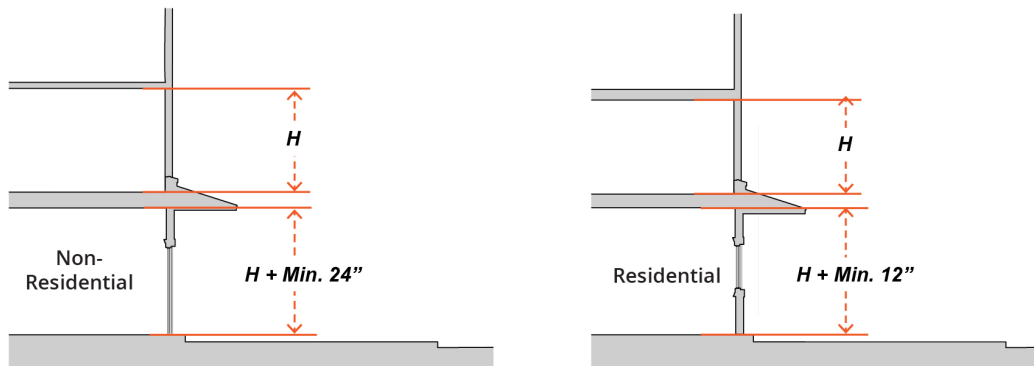

4. **Interior Courtyard.** Interior courtyards must be:
 - a. Partially visible from the street and linked to the street by a clear accessible path of travel.
 - b. Enclosed on at least two sides by buildings
 - c. Open to the sky (arbors and trellises are allowed)
 - d. A minimum width of 20 feet and a minimum area of 400 square feet.
5. **Paseos.** Paseos must be:
 - a. A minimum width of 10 feet for through-block paseos
 - b. A minimum width of 4 feet for entries to courtyards or individual single businesses.

D. Window Design.

1. Window frames, backbands, and sills.
 - a. All windows shall have a sill.
 - i. The sill shall extend horizontally beyond the window opening or frame/casing (if present) at each end.
 - ii. The sill shall be sloped toward the outside.
 - iii. The sill shall have a drip at its outer edge.
2. Vinyl windows are prohibited on facades visible from a right-of-way.
3. Tinted glass is not allowed.

E. Building Materials.

1. Primary shall mean 50 percent or more of a façade surface area excluding transparent surfaces. The following primary cladding materials are allowed:
 - a. Stucco (minimum 2-coat stucco; synthetic stucco or EIFS not allowed)
 - b. Siding (lap, vertical, panelized, or shingle)
 - i. All siding shall be wood, composite wood, or cement fiberboard.
 - ii. Wood siding shall be painted or stained.
 - iii. Vinyl and aluminum not permitted.
 - c. Stone
 - d. Brick
2. Secondary shall mean less than 50 percent of a façade surface area excluding transparent surfaces. The following secondary cladding materials are allowed:
 - a. Stucco (minimum 2-coat stucco; synthetic stucco not allowed, EIFS not allowed)
 - b. Siding (lap, vertical, panelized, or shingle)
 - i. All siding shall be wood, composite wood, or cement fiberboard.

- ii. Wood siding shall be painted or stained.
- iii. Vinyl and aluminum siding are not permitted.
- c. Stone (building base only)
- d. Brick (building base only)
- e. Tile (for bulkheads below display windows and decorative accents only)
- f. Metal (matte finish or Cor-ten)
 - i. Ribbed metal, titanium, and mirrored finishes are not permitted.
- g. Concrete Masonry Units (watertable and building base only, and not allowed on any façade facing a right-of-way or a single-family zone)
- h. Concrete (building base only, board-form only, cast concrete not permitted).

F. Ground Level Open Space. Where any required front, rear, or side yard setback is 10 feet or greater, on-site ground-level open space shall be provided within the setback.

- 1. The ground level open space shall be usable and accessible.
- 2. The minimum dimension for ground level open space shall be 8 feet.

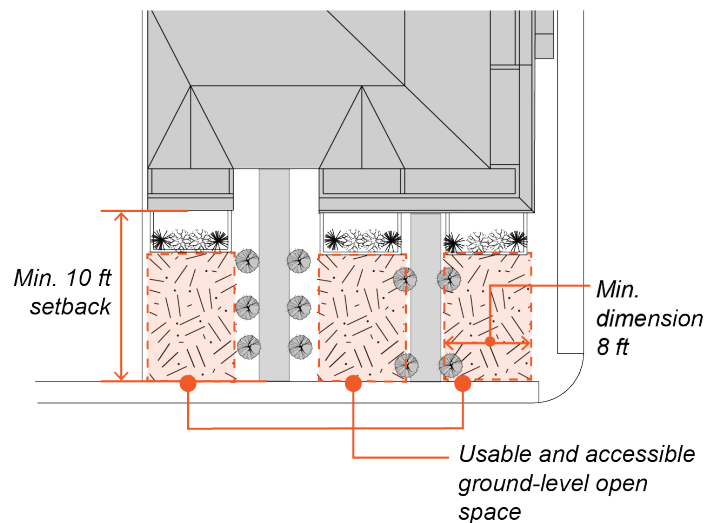

G. Landscaping, Paving and Pedestrian Amenities.

- 1. Landscape elements shall be integrated with the building architecture, parking, and streetscape. Recommended patterns shall include, but are not limited to:
 - a. Planters for flowers and shrubs within street frontage.
 - b. Landscape buffers between parking spaces and building facades.
 - c. Landscaping within and/or on walls adjacent to courtyards, open spaces, and setbacks.
- 2. Within the Loyola Corners Specific Plan Overlay district, landscaping, paving and pedestrian amenities shall be as specified in the Loyola Corners Specific Plan.

Revised 14.40.150 Design Control (CN)

3. See Sections 14.66.180 (Maintenance of Landscaped Areas) and 14.70.070 (Landscaped Strips) for additional landscaping standards.

H. Site Circulation and Access

1. New development on abutting lots shall be designed to allow cross-access for internal pedestrian, bicycle, and vehicular circulation systems.
2. Bicycle racks shall be provided:
 - a. In or within 50 feet of every parking area; and
 - b. Within 20 feet of at least one building entrance.

I. Service Areas and Screening.

1. Service areas must be located at the rear of lot.
2. Service areas must be enclosed in enclosures that are architecturally consistent with primary building in terms of materials, colors, and style.

J. Additional Design Standards. See Section 14.66.280 for additional design standards applicable to all residential mixed-use development in the CN District.

Revised 14.44.130 Design Control (CD)

A. Building Massing and Articulation.

1. Upper-story Step-backs.

- a. *Front:* Minimum 10 feet from ground floor façade above 30 feet in height.

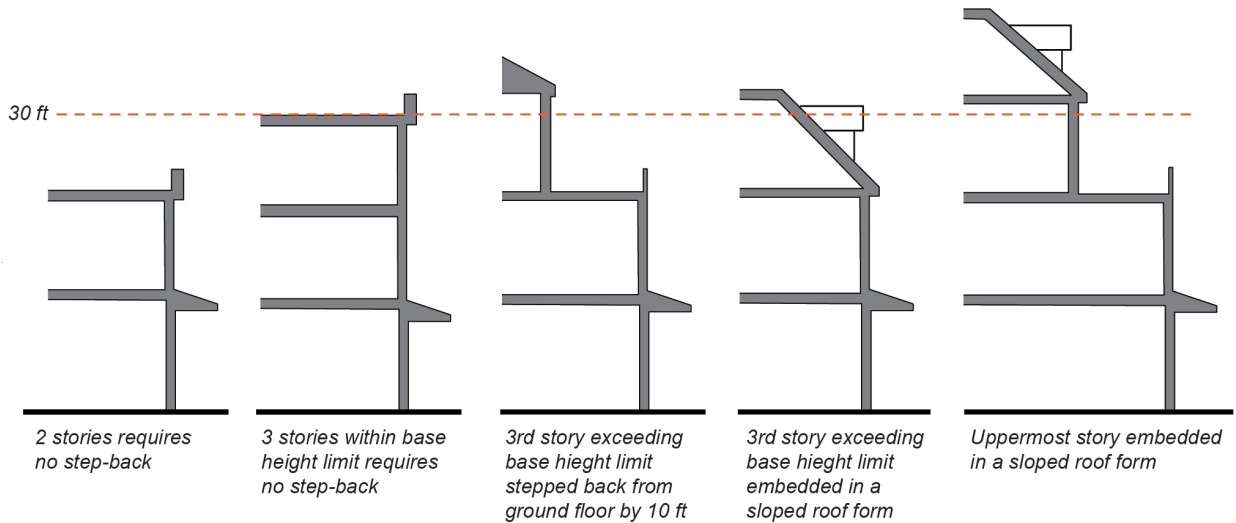

- b. *Street Side:* Minimum 10 feet from ground floor façade above 30 feet in height.
- c. For buildings over three stories in height, the uppermost story must be embedded in a sloped roof form such as a mansard roof or a hipped and/or gabled roof with dormers, as allowed by standards in Section 14.44.130.A.6.

2. Vertical Articulation.

- a. When a building façade exceeds 75 feet in length along a right of way, it must be separated into primary façade bays no greater than 50 feet and secondary façade bays defined by a recess a minimum of 3 feet deep.
- b. A minimum one entrance shall be provided per primary façade bay.
- c. The eave/roof of a secondary façade bay shall be no higher than the corresponding elements of the primary façade bay.

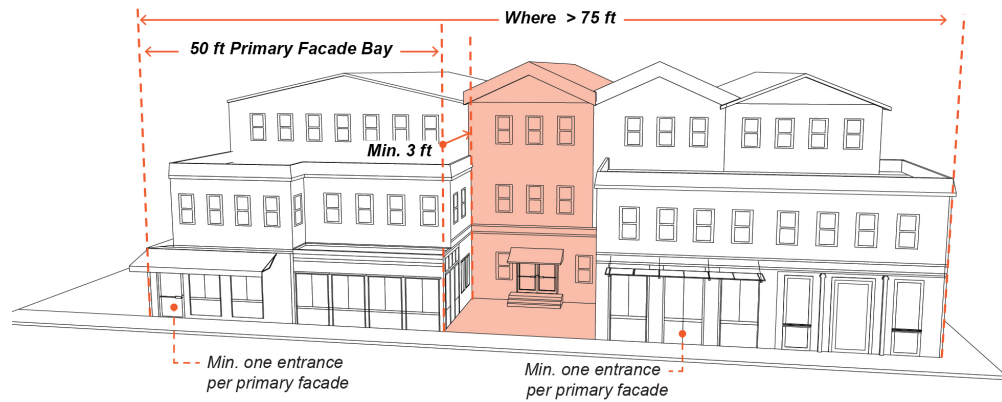

3. **Horizontal Articulation.** New facades and façade modifications along a street or civic space shall be designed to visually express a base, middle, and top.
 - a. One or more of the following patterns shall be used to define the base:
 - i. Watertable: Base material extends from grade to between 8 and 54 inches above grade.
 - ii. Podium: The base material encompasses the lowest story (or stories) of the building, with or without mezzanine(s), and terminates in a sill, string course, or cornice at its upper bound (multi-story buildings only).
 - iii. Watertable + Cornice/String Course: A watertable using the base material is combined with a cornice or string course at the lowest story's upper bound, including any mezzanine (multi-story buildings only).
 - b. The top of each building mass/bay shall be defined by elements spanning the full length of the façade of the mass/bay. Such elements may include a cornice, eave and/or gable(s), or other elements listed under Section 17.44.130.A.6. These elements shall be consistent with the overall architectural style of the building mass/bay.



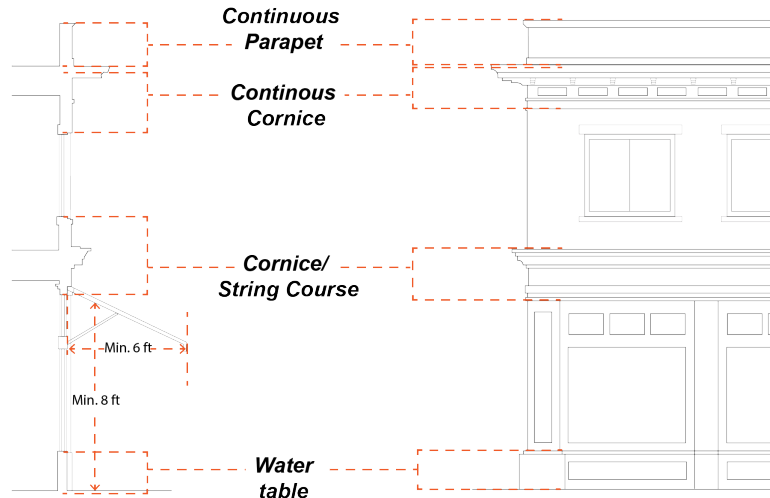

4. **Adjacencies.**

a. *Storefront Facades Adjacent to Storefront Facades.*

- i. The height of a storefront shall not differ from the height of any adjacent storefront by more than 2 feet.
- ii. The height of ground story shall not differ from height of any adjacent ground story by more than 2 feet.
- iii. Storefronts may transition in height using a module of 25 feet in length along a right-of-way.

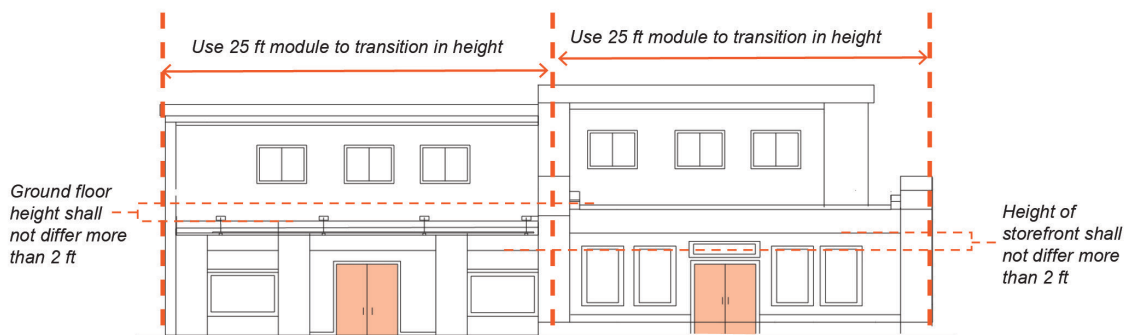

b. *Compatibility with Adjacent Shorter Buildings with Height Difference of One Story or More.* When adjacent to an existing shorter building with a height difference of one story or more, a proposed building must utilize two or more of the following strategies:

- i. Incorporate the uppermost floor into the roof form
- ii. Break the mass of the building into smaller modules through changes in wall plane, setbacks, and/or height
- iii. Match window heights and/or proportions
- iv. Relate roof cornices and moldings at floor lines

5. **Privacy and Line of Sight.**

- a. Primary living spaces and balconies located along a side setback shall orient principal windows and balconies toward the front and rear of the building.
- b. Where windows are within 10 feet of and oriented toward an interior side setback, glazing shall either be a minimum 30-degree angle measured perpendicular to the adjacent side setback line, have minimum sill height of 42 inches, or be opaque.
- c. The maximum sill height for an ingress/egress window is 44 inches from finished floor.

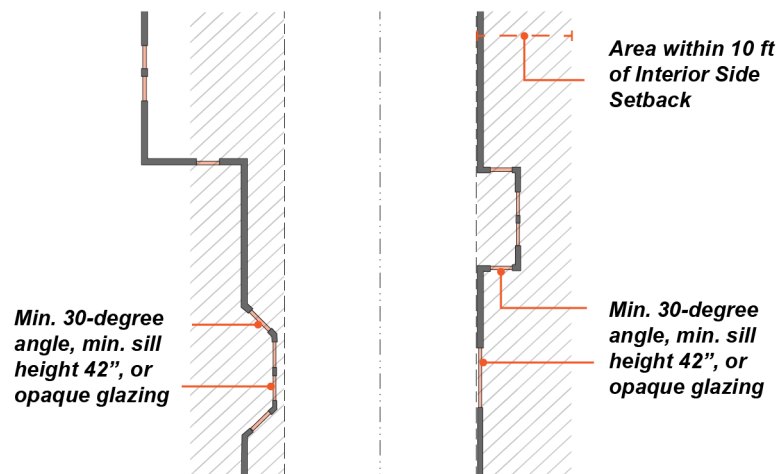

6. **Roofline and Roof Design.**

- a. Roof designs shall be limited to:
 - i. Hipped
 - ii. Gable
 - iii. Mansard
 - (a) Applicable for buildings 3 or more stories.
 - iv. Dormer
 - v. Parapet.
 - (a) When used on the first or second floor, a parapet longer than 25 feet in length must include at least one but not more than two of the following design elements to break up the length of the parapet:
 - (1) Steps
 - (2) Curves
 - (3) Angled surfaces
 - (b) The length of a parapet segment on the third floor and above may not exceed 25 feet.

- b. When the top story is stepped back and embedded in a sloped roof form such as a mansard roof or a hipped and/or gabled roof with dormers, the floor below must (and other floors may) be stepped back to meet the slope of the top story.

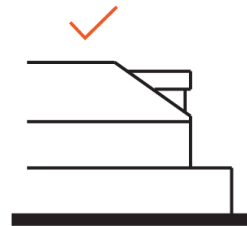

Acceptable:
One story below the story embedded in a sloped roof is also stepped-back .

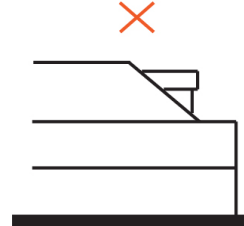

Not acceptable:
Top story embedded in a sloped roof is the only story stepped back.

- c. Building façades facing an R-1 district must have a hipped or gable roof and may incorporate dormers.
- d. Roofline/parapet at corners shall not exceed roofline/parapet of adjacent wallplanes by more than 24 inches.

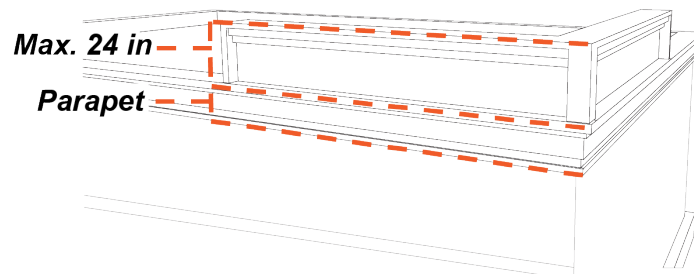

B. Building Design.

1. Façade Design.

- a. Building facades must continue the pattern established by existing buildings in Downtown Los Altos by reinforcing the underlying maximum 50-foot module along all street frontages through the use of the following techniques:
- i. Building facades shall be arranged in an orderly composition of bays, defined by vertically aligned openings alternating horizontally with solid walls or columns. The pattern shall be visually expressed through the spacing of openings, recesses, eaves, inset panels, cornices, overhangs, trellises, exposed rafters, columns, or bay windows.
 - ii. The pattern may be shared between the ground floor and upper stories provided the ground floor exhibits enhanced detail or modulation.
 - iii. Residential facades shall incorporate at least one element that signals habitation, such as bay windows, or balconies.

- iv. Non-glazed wall areas (blank walls) at the ground level must be enhanced with architectural details, landscaping, and/or landscaped trellises or lattices.
 - b. At least two of the following strategies must be used in a manner that reinforces the maximum 50-foot module:
 - i. Change in roof parapet height or shape.
 - ii. Change in roof style
 - iii. Change in materials palette
 - iv. Change in building height, minimum 8-foot difference.
 - v. Change in frontage type or change in details of Shopfront frontage type if used.
 - vi. Use of upper floor projections such as bay windows or balconies.
2. **Ground Level Transparency.** A minimum 60 percent of commercial ground floor street-facing facades between 2 and 7 feet in height shall be transparent window surface. Opaque, reflective, or dark tinted glass is not allowed.

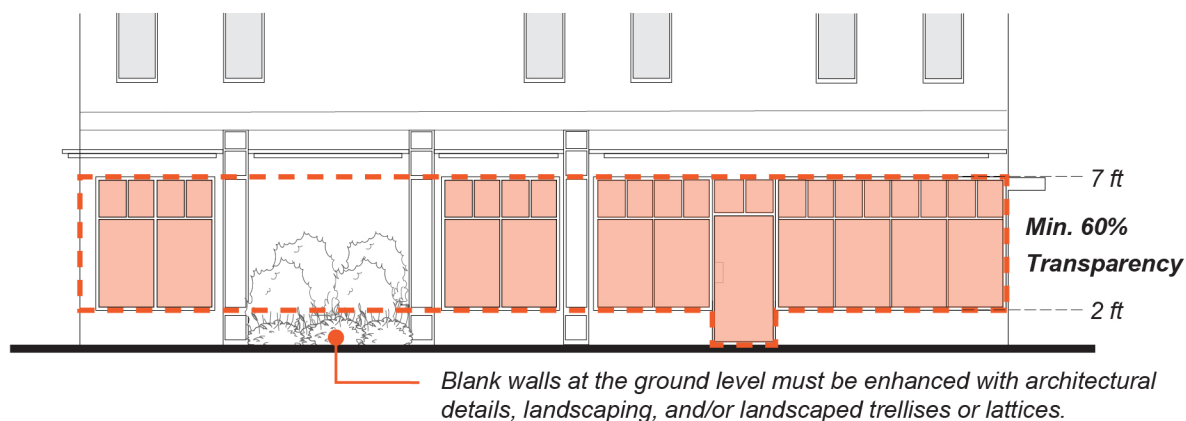

3. **Pedestrian-Scaled Entrances.**
- a. Building entrances must incorporate at least one of the following entry features. See Section 14.66.275 (Entrance Type Standards) for design standards applicable to each entrance type listed.
 - i. Stoop
 - ii. Dooryard
 - iii. Shopfront
 - (a) Shopfronts more than 25 feet in width must incorporate variations in bulkhead, awnings, materials and/or color to visually articulate the shopfront into modules not to exceed 25 continuous feet.
 - iv. Gallery

v. Arcade

vi. Forecourt

- (a) Forecourts must feature at least one entry to a shop and/or second floor use.
- (b) Forecourts for buildings more than 70 feet in length along a right-of-way must have a minimum width and depth of 15 feet from front façade. Width of forecourt shall be equal to or greater than depth.
- (c) The size of the forecourt must be appropriate relative to the size of the building. The maximum ratio of building height to forecourt is 2:1 (height < 2 x width).
- (d) Forecourt must be enclosed on at least three sides by buildings.
- (e) Forecourt must remain open to the sky (arbors and trellises are allowed).

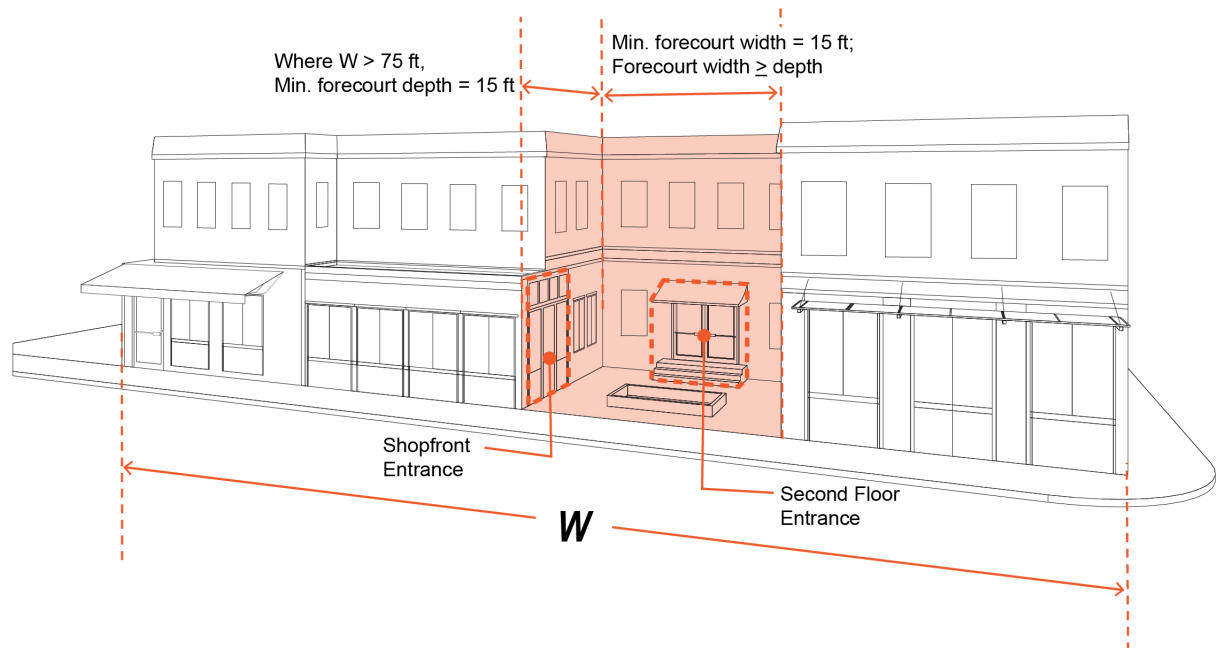

vii. Terrace

- b. *Primary Entrance Location(s)*. Locate primary entrance on the front right-of-way and/or in the interior courtyard.
- c. *Individual Entries*. Ground floor residential units facing a street must provide individual entries along the street frontage.
- d. *Corner Entrances*. Chamfered corners must incorporate a building entrance. Any required entrances may be provided on the corner of the building assuming one of the intersecting sides is a primary frontage.

- e. *Street-facing Entries to Upper Floors.* Street-facing entries to upper floors shall be equal in quality and detail to storefronts. This standard may be satisfied through two or more of the following:
 - i. Dedicated awning, canopy, or other roof element
 - ii. Stairs with a single color applied to treads and a contrasting color or pattern applied to risers.
 - iii. Dedicated light fixture(s)
 - iv. Decorative street address numbers or tiles
 - v. Plaque signs for upper-floor business tenants
- f. *Entry Protection.* Primary street-facing entrances shall be protected by a recess in the building frontage at least 3 feet deep or by a projection extending outward at least 3 feet measured horizontally from the entrance, and wide enough to clear the building entryway on both sides.
 - i. Protection may be coterminous with an accent element.
 - ii. Protection may take the form of an extended eave, overhang, awning, door canopy, gallery, arcade frontage, or other element that provides shade and shelter from the elements.
 - iii. The lowest edge of a projecting awning or door canopy shall have a vertical clearance of no more than 8 feet.
 - iv. Recessed entries shall differentiate pavement within the recess through the use of a dedicated paving material or pattern.

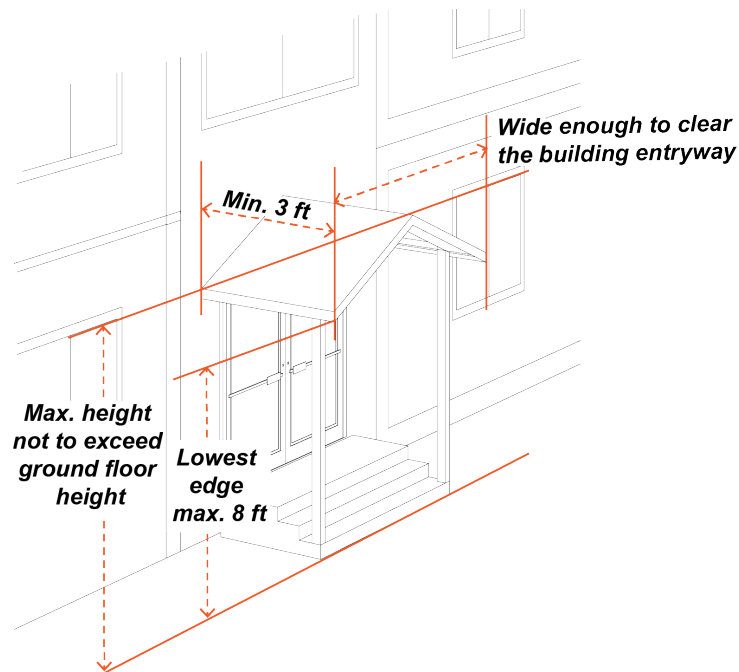

- g. Accent elements demarcating building frontage, entrance, and common open space areas shall not exceed the height of the ground floor story. Roof elements are excepted.

4. **Ground Floor Floor-to-Ceiling Height.**
 - a. Minimum 24 inches taller than typical upper floor floor-to-ceiling height where ground floor is non-residential.
 - b. Minimum 12 inches taller than typical upper floor floor-to-ceiling height where ground floor is residential.

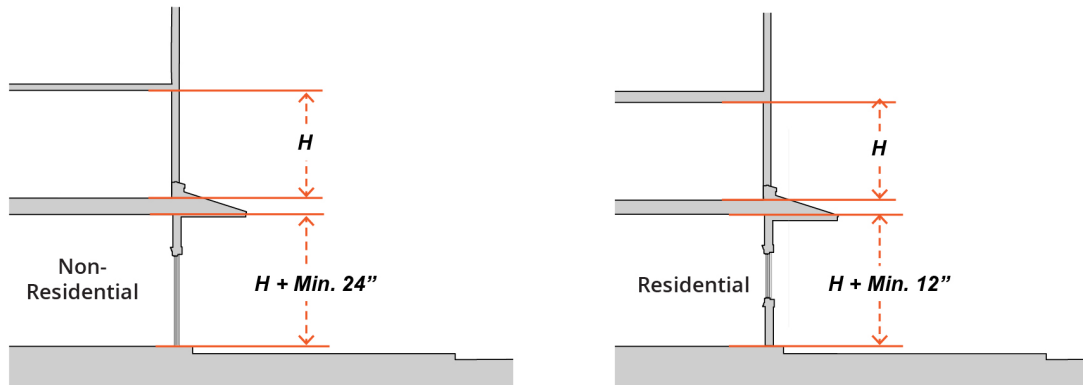

5. **Interior Courtyard.** Interior courtyards must be:
 - a. Partially visible from the street and linked to the street by a clear accessible path of travel.
 - b. Enclosed on at least two sides by buildings
 - c. Open to the sky (arbors and trellises are allowed)
 - d. A minimum width of 20 feet and a minimum area of 400 square feet.
6. **Paseos.** Paseos must be:
 - a. A minimum width of 10 feet for through-block paseos.
 - b. A minimum width of 4 feet for entries to courtyards or individual single businesses.

C. Window Design.

1. Window frames, backbands, and sills.
 - a. All windows shall have a sill.
 - i. The sill shall extend horizontally beyond the window opening or frame/casing (if present) at each end.
 - ii. The sill shall be sloped toward the outside.
 - iii. The sill shall have a drip at its outer edge.
2. Vinyl windows are prohibited on facades visible from a right-of-way.

D. Building Materials.

1. Primary shall mean 50 percent or more of a façade surface area excluding transparent surfaces. The following primary cladding materials are allowed:

Revised 14.44.130 Design Control (CD)

- a. Stucco (minimum 2-coat stucco; synthetic stucco or EIFS not allowed)
 - b. Siding (lap, vertical, panelized, or shingle)
 - i. All siding shall be wood, composite wood, or cement fiberboard.
 - ii. Wood siding shall be painted or stained.
 - iii. Vinyl and aluminum siding are not allowed.
 - c. Stone
 - d. Brick
2. Secondary shall mean less than 50 percent of a façade surface area excluding transparent surfaces. The following secondary cladding materials are allowed:
- a. Stucco (minimum 2-coat stucco; synthetic stucco not allowed, EIFS not allowed)
 - b. Siding (lap, vertical, panelized, or shingle)
 - i. All siding shall be wood, composite wood, or cement fiberboard.
 - ii. Wood siding shall be painted or stained.
 - iii. Vinyl and aluminum siding are not permitted.
 - c. Stone (building base only)
 - d. Brick (building base only)
 - e. Tile
 - f. Metal (matte finish or Cor-ten)
 - i. Ribbed metal, titanium, and mirrored finishes are not permitted.
 - g. Concrete Masonry Units (watertable and building base only, and not allowed on any façade facing a right-of-way or a single-family zone).
 - h. Concrete (building base only, board-form only, cast concrete not permitted).

E. Landscaping, Paving, and Pedestrian Amenities.

- 1. Landscaping must be placed on each side of a driveway at grade or in raised planters.
- 2. All paving located adjacent to a sidewalk must be textured (decorative or permeable).
- 3. A minimum 75 percent of on-site paving material must be pervious/permeable.
- 4. Landscape elements shall be integrated with the building architecture, parking, and streetscape. Recommended patterns shall include, but are not limited to:
 - a. Planters for flowers and shrubs within street frontage.
 - b. Landscape buffers between parking spaces and building facades.
 - c. Landscaping within and/or on walls adjacent to courtyards, open spaces, and setbacks. A publicly visible and accessible pedestrian amenity such as benches, a fountain, a rain garden, decorative paving, and/or public art.

5. See Sections 14.66.180 (Maintenance of Landscaped Areas) and 14.70.070 (Landscaped Strips) for additional landscaping standards.

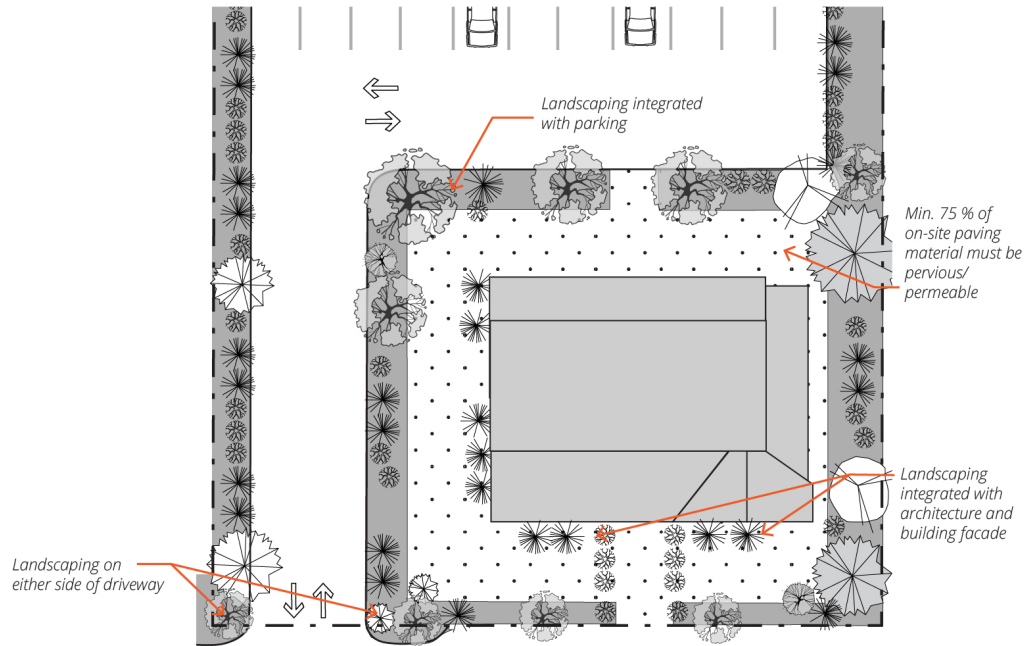

F. Parking Design and Access.

1. Where structured parking is provided, the parking area must be either:
 - a. "Lined" with ground-floor non-residential uses at least 30 feet deep as measured from the front façade; or

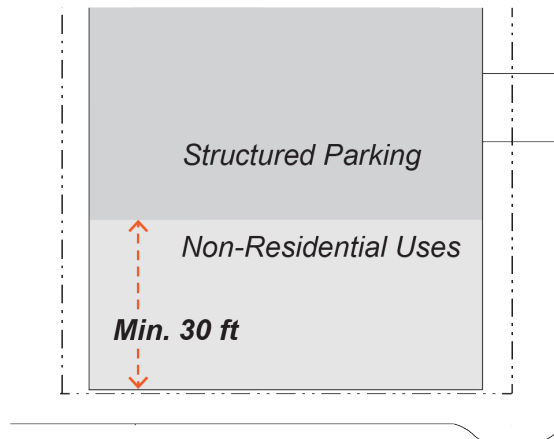

- b. Designed such that the floor elevation is a minimum 4 vertical feet below the elevation of the adjacent sidewalk.

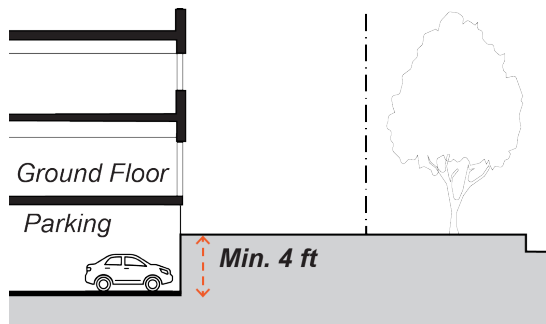

- 2. Visible structured parking must be screened from view from the right-of-way by at least one of the following features:
 - a. Regular punched openings designed to resemble windows of habitable spaces
 - b. Trellis/living wall
 - c. Custom textured or decorative screening
- 3. **Entrances to Parking Facilities.**
 - a. A maximum of two curb cuts for one-way traffic and one curb cut for two-way traffic may be permitted per street frontage per lot.
 - b. Controlled entrances to parking facilities (gates, doors, etc.) shall be located a minimum 10 feet from the back of sidewalk.
 - c. Entrances to parking facilities along a street frontage shall be separated by a minimum of 40 feet, excluding access to parking plazas.
 - d. Where possible, curb cuts serving adjacent parking facilities shall be shared.

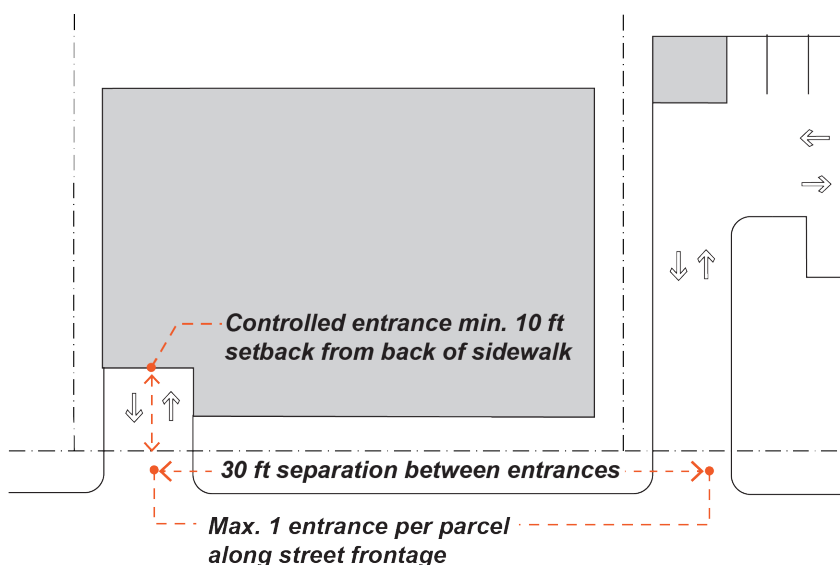

G. Site Circulation and Access.

1. A clearly defined, lighted and landscaped pedestrian route shall be provided between all parking areas and primary pedestrian entrance.
2. New development on abutting lots shall be designed to allow cross-access for internal pedestrian, bicycle, and vehicular circulation systems.
3. Bicycle racks shall be provided:
 - a. In or within 50 feet of every parking area; and
 - b. Within 20 feet of at least one building entrance.

H. Service Areas and Screening.

1. Service areas must be located at the rear of lot or along a parking plaza.
2. Service areas must be enclosed in enclosures that are architecturally consistent with primary building in terms of materials, colors, and style.

I. Additional Design Standards. See Section 14.66.280 for additional design standards applicable to all residential mixed-use development in the CD District.

Revised 14.48.130 Design Control (CRS)

A. Building Massing and Articulation.

1. *Upper-story Step-backs, Front and Street Side.*

- a. The third story must be either stepped back a minimum 5 feet from the ground floor façade or embedded in a sloped roof form such as a mansard roof or a hipped and/or gabled roof with dormers, as allowed by standards in Section 14.48.130.A.6.
- b. For buildings over three stories, the uppermost story must be embedded in a sloped roof form such as a mansard roof or a hipped and/or gabled roof with dormers, as allowed by standards in Section 14.48.130.A.6.

2. *Vertical Articulation.*

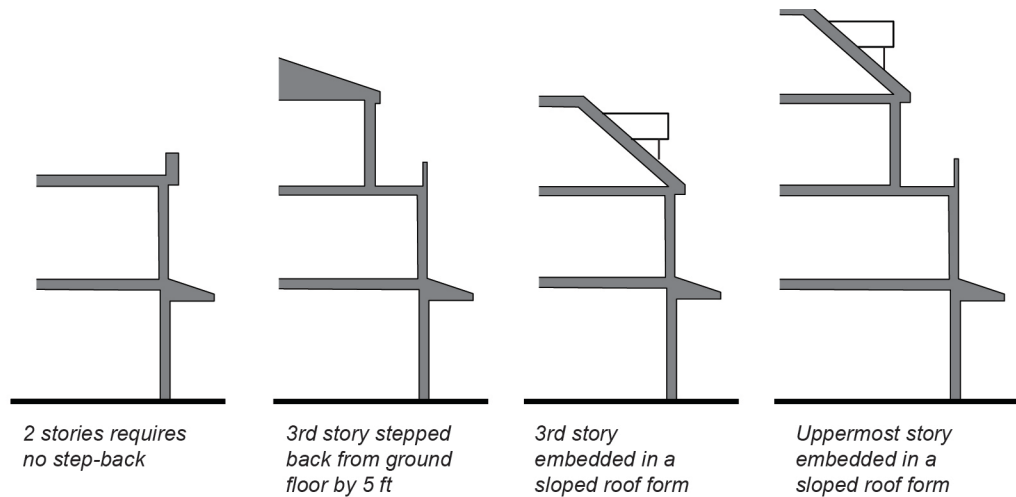

- a. When a building façade exceeds 50 feet in length along a right of way, it must be separated into primary façade bays no greater than 50 feet and secondary façade bays defined by a recess a minimum of 3 feet deep.
- b. The building shall include at least one ground-floor entrance every 25 feet.

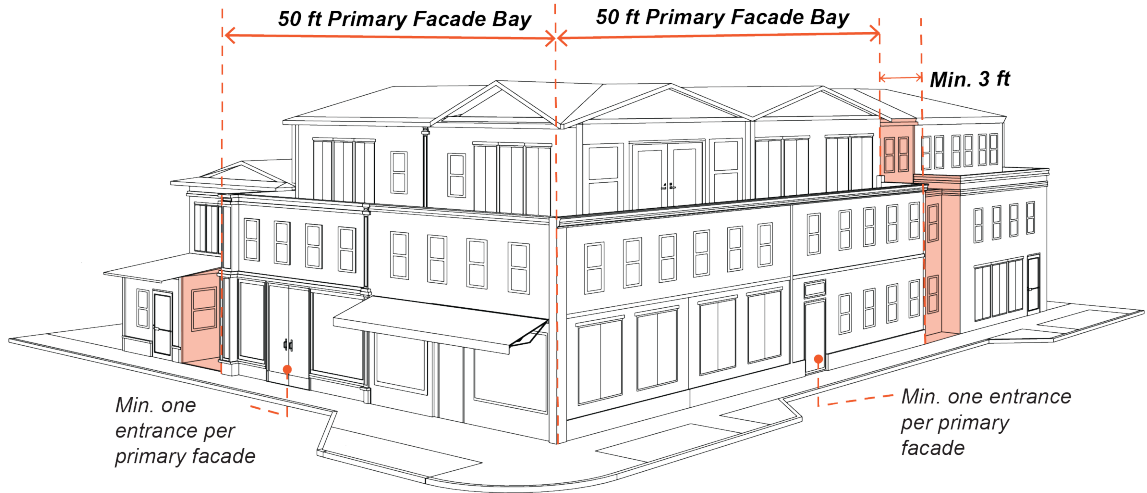

3. **Horizontal Articulation.** New facades and façade modifications along a street or civic space shall be designed to visually express a base, middle, and top.
 - a. One or more of the following patterns shall be used to define the base:
 - i. Watertable: Base material extends from grade to between 8 and 54 inches above grade.
 - ii. Podium: The base material encompasses the lowest story (or stories) of the building, with or without mezzanine(s), and terminates in a sill, string course, or cornice at its upper bound (multi-story buildings only).
 - iii. Watertable + Cornice/String Course: A watertable using the base material is combined with a cornice or string course at the lowest story's upper bound, including any mezzanine (multi-story buildings only).

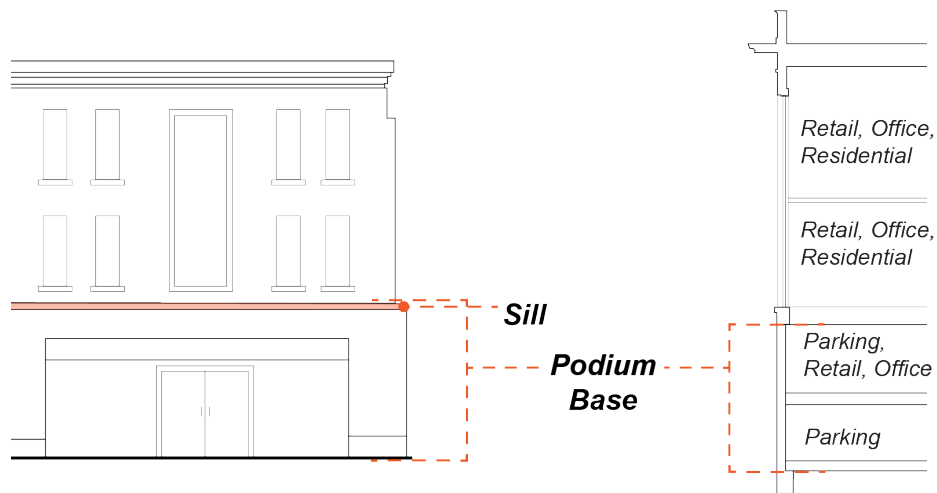

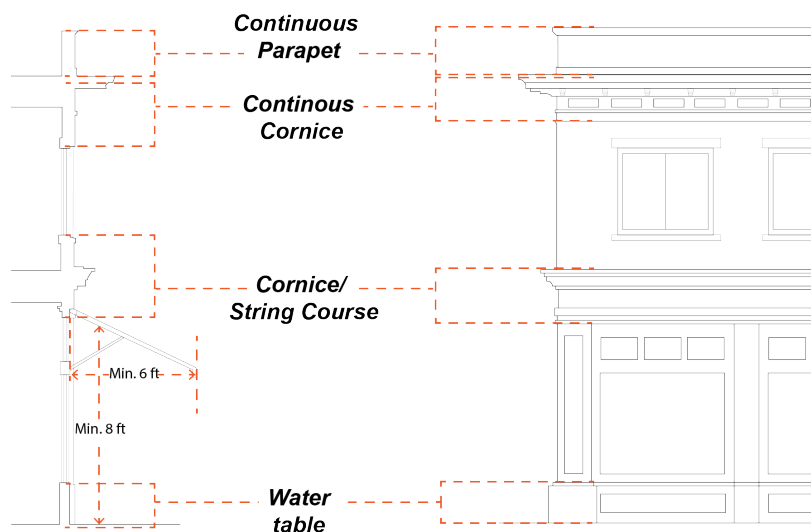

- b. The top of each building mass/bay shall be defined by elements spanning the full length of the façade of the mass/bay. Such elements may include a cornice, eave and/or gable(s), or other elements listed under Section 17.48.130.B.7. These elements shall be consistent with the overall architectural style of the building mass/bay.

4. **Adjacencies.**

a. *Storefront Facades Adjacent to Storefront Facades.*

- i. The height of a storefront shall not differ from the height of any adjacent storefront by more than 2 feet.
- ii. The height of ground story shall not differ from height of any adjacent ground story by more than 2 feet.
- iii. Storefronts may transition in height using a module of 25 feet in length along a right-of-way.

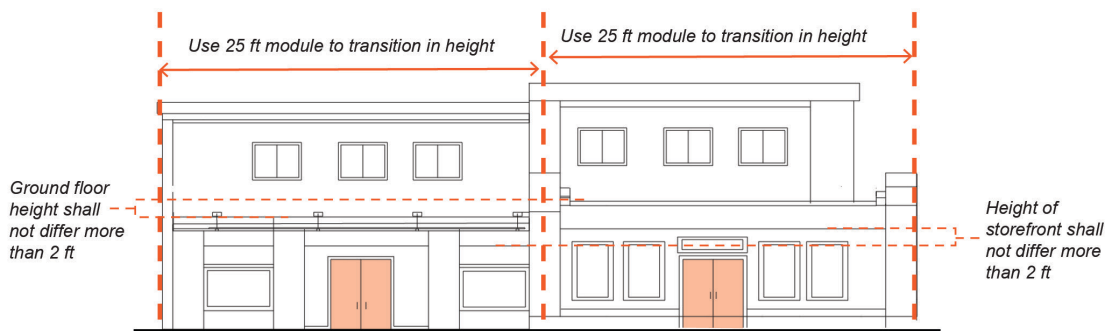

- b. *Compatibility with Adjacent Shorter Buildings with Height Difference of One Story or More.* When adjacent to an existing shorter building with a height difference

of one story or more, a proposed building must utilize two or more of the following strategies:

- i. Incorporate the uppermost floor into the roof form
- ii. Break the mass of the building into smaller modules through changes in wall plane, setbacks, and/or height
- iii. Match window heights and/or proportions
- iv. Relate roof cornices and moldings at floor lines

5. **Privacy and Line of Sight.**

- a. Primary living spaces and balconies located along a side setback shall orient principal windows and balconies toward the front and rear of the building.
- b. Where windows are within 10 feet of and oriented toward an interior side setback, glazing shall either be a minimum 30-degree angle measured perpendicular to the adjacent side setback line, have minimum sill height of 42 inches, or be opaque.
- c. The maximum sill height for an ingress/egress window is 44 inches from finished floor.

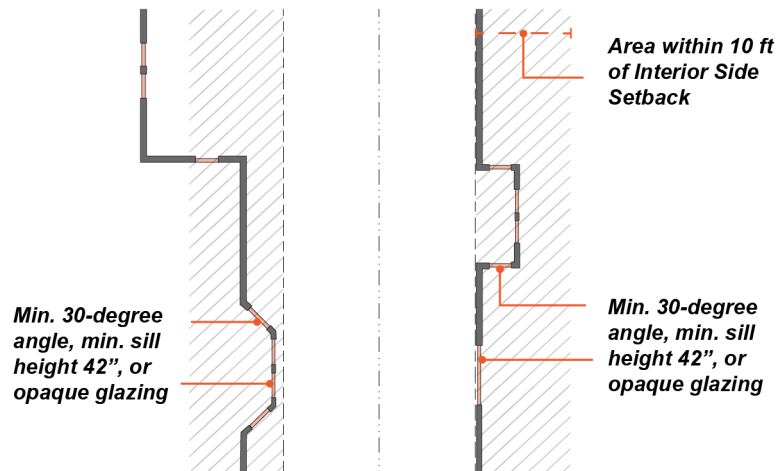

6. **Roofline and Roof Design.**

- a. Roof designs shall be limited to:
 - i. Hipped
 - ii. Gable
 - iii. Dormer
 - iv. Parapet.
 - (a) When used on the first or second floor, a parapet longer than 25 feet in length must include at least one but not more than

two of the following design elements to break up the length of the parapet:

- (1) Steps
- (2) Curves
- (3) Angled surfaces

(b) The length of a parapet segment on the third floor and above may not exceed 25 feet.

- b. Building façades facing an R-1 district must have a hipped or gable roof and may incorporate dormers.
- c. Roofline/parapet at corners shall not exceed roofline/parapet of adjacent wallplanes by more than 24 inches.

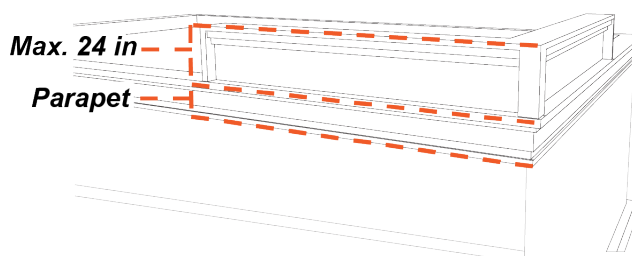

B. Building Design.

1. Façade Design.

- a. Building facades must continue the pattern established by existing buildings in Downtown Los Altos by reinforcing the underlying maximum 25-foot module along all street frontages through the use of the following techniques:
 - i. Building facades shall be arranged in an orderly composition of bays, defined by vertically aligned openings alternating horizontally with solid walls or columns. The pattern shall be visually expressed through the spacing of openings, recesses, eaves, inset panels, cornices, overhangs, trellises, exposed rafters, columns, or bay windows.
 - ii. The pattern may be shared between the ground floor and upper stories provided the ground floor exhibits enhanced detail or modulation.
 - iii. Residential facades shall incorporate at least one element that signals habitation, such as bay windows, or balconies.
 - iv. Non-glazed wall areas (blank walls) at the ground level must be enhanced with architectural details, landscaping, and/or landscaped trellises or lattices.
- b. At least two of the following strategies must be used in a manner that reinforces the maximum 25-foot module:
 - i. Change in roof parapet height or shape

- ii. Change in roof style
 - iii. Change in materials palette
 - iv. Change in building height, minimum 8-foot difference
 - v. Change in frontage type or change in details of Shopfront frontage type if used
 - vi. Use of upper floor projections such as bay windows or balconies.
2. **Ground Level Transparency.** A minimum 60 percent of commercial ground floor street-facing facades between 2 and 7 feet in height shall be transparent window surface. Opaque, reflective, or dark tinted glass is not allowed.

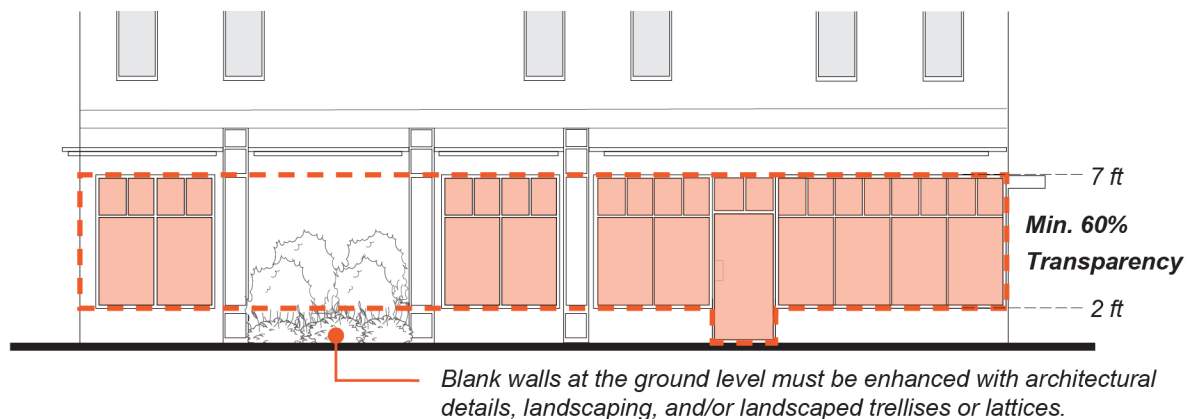

3. **Pedestrian-Scaled Entrances.**
- a. Building entrances must incorporate at least one of the following entry features. See Section 14.66.275 (Entrance Type Standards) for design standards applicable to each entrance type listed.
 - i. Stoop
 - ii. Shopfront
 - (a) The maximum width of single shopfront shall be 25 feet.
 - iii. Gallery
 - iv. Arcade with Shopfront frontage.
 - b. *Primary Entrance Location(s).* Locate primary entrance on the front right-of-way.
 - c. *Corner Entrances.* Chamfered corners must incorporate a building entrance. Any required entrances may be provided on the corner of the building assuming one of the intersecting sides is a primary frontage.
 - d. *Street-facing Entries to Upper Floors.* Street-facing entries to upper floors shall be equal in quality and detail to storefronts. This standard may be satisfied through two or more of the following:
 - i. Dedicated awning, canopy, or other roof element

- ii. Stairs with a single color applied to treads and a contrasting color or pattern applied to risers.
 - iii. Dedicated light fixture(s)
 - iv. Decorative street address numbers or tiles
 - v. Plaque signs for upper-floor business tenants
- e. *Entry Protection.* Primary street-facing entrances shall be protected by a recess in the building frontage at least 3 feet deep or by a projection extending outward at least 3 feet measured horizontally from the entrance, and wide enough to clear the building entryway on both sides.
- i. Protection may be coterminous with an accent element.
 - ii. Protection may take the form of an extended eave, overhang, awning, door canopy, gallery, arcade frontage, or other element that provides shade and shelter from the elements.
 - iii. The lowest edge of a projecting awning or door canopy shall have a vertical clearance of no more than 8 feet.
 - iv. Recessed entries shall differentiate pavement within the recess through the use of a dedicated paving material or pattern.

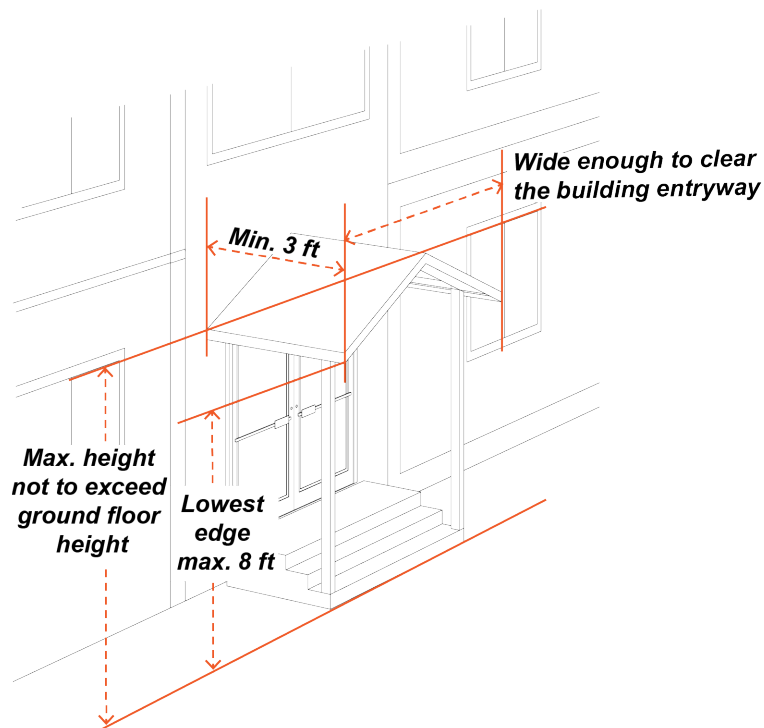

- f. Accent elements demarcating building frontage, entrance, and common open space areas shall not exceed the height of the ground floor story. Roof elements are exempted.

4. **Ground Floor Floor-to-Ceiling Height.** Minimum 24 inches taller than typical upper floor floor-to-ceiling height.

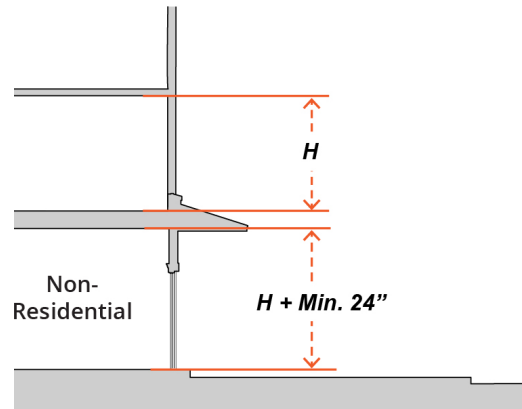

5. **Interior Courtyard.** Interior courtyards must be:
 - a. Partially visible from the street and linked to the street by a clear accessible path of travel.
 - b. Enclosed on at least two sides by buildings.
 - c. Open to the sky (arbors and trellises are allowed)
 - d. A minimum width of 20 feet and a minimum area of 400 square feet.
6. **Paseos.** Paseos must be:
 - a. A minimum width of 10 feet for through-block paseos.
 - b. A minimum width of 4 feet for entries to courtyards or individual single businesses.

C. Window Design.

1. Window frames, backbands, and sills.
 - a. All windows shall have a sill.
 - i. The sill shall extend horizontally beyond the window opening or frame/casing (if present) at each end.
 - ii. The sill shall be sloped toward the outside.
 - iii. The sill shall have a drip at its outer edge.
2. Vinyl windows are prohibited on facades visible from a right-of-way.
3. Tinted glass is not allowed.

D. Building Materials.

1. Primary shall mean 50 percent or more of a façade surface area excluding transparent surfaces. The following primary cladding materials are allowed:
 - a. Stucco (minimum 2-coat stucco; synthetic stucco or EIFS not allowed)
 - b. Siding (lap, vertical, or shingle)

Revised 14.48.130 Design Control (CRS)

- i. All siding shall be wood, composite wood, or cement fiberboard.
 - ii. Wood siding shall be painted or stained.
 - iii. Vinyl and aluminum siding are not permitted.
 - c. Stone
 - d. Brick
 - 2. Secondary shall mean less than 50 percent of a façade surface area excluding transparent surfaces. The following secondary cladding materials are allowed:
 - a. Stucco (minimum 2-coat stucco; synthetic stucco not allowed, EIFS not allowed)
 - b. Siding (lap, vertical, or shingle)
 - i. All siding shall be wood, composite wood, or cement fiberboard.
 - ii. Wood siding shall be painted or stained.
 - iii. Vinyl and aluminum siding are not permitted.
 - c. Stone (building base only)
 - d. Brick (building base only)
 - e. Tile (for bulkheads below display windows and decorative accents only)
 - f. Metal (Matte finish or Cor-ten)
 - i. Ribbed metal, titanium, and mirrored finishes are not permitted.
 - g. Concrete Masonry Units (building base only, and not allowed on any façade facing a right-of-way or a single-family zone)
 - h. Concrete (watertable and building base only, board-form only, cast concrete not permitted).
- E. Downtown Gateways.** A downtown gateway is located at the intersection of Foothill Expressway at Main Street.
- 1. Building design at gateway intersection shall include:
 - a. Façade lighting; and
 - b. Overhangs or sloped roof forms.
 - 2. Ground-floor design at gateway intersections must address both street frontages through:
 - a. Entrances that are visible and directly accessible from both streets;
 - b. Building transparency beyond the required minimum for the first 15 feet of building frontage from the corner;
 - c. Landscaped area with a minimum dimension of six feet; and
 - d. A usable public space with pedestrian-scaled features.

F. Landscaping and Paving, and Pedestrian Amenities.

1. Landscaping must be placed on each side of a driveway at grade or in raised planters.
2. All paving located adjacent to a sidewalk must be textured (decorative or permeable).
3. A minimum 75 percent of on-site paving material must be pervious/permeable.
4. Landscape elements shall be integrated with the building architecture, parking, and streetscape. Recommended patterns shall include, but are not limited to:
 - a. Planters for flowers and shrubs within street frontage.
 - b. Landscape buffers between parking spaces and building facades.
 - c. Landscaping within and/or on walls adjacent to courtyards, open spaces, and setbacks.
 - d. A publicly visible and accessible pedestrian amenity such as benches, a fountain, a rain garden, decorative paving, and/or public art.
5. See Sections 14.66.180 (Maintenance of Landscaped Areas) and 14.70.070 (Landscaped Strips) for additional landscaping standards.

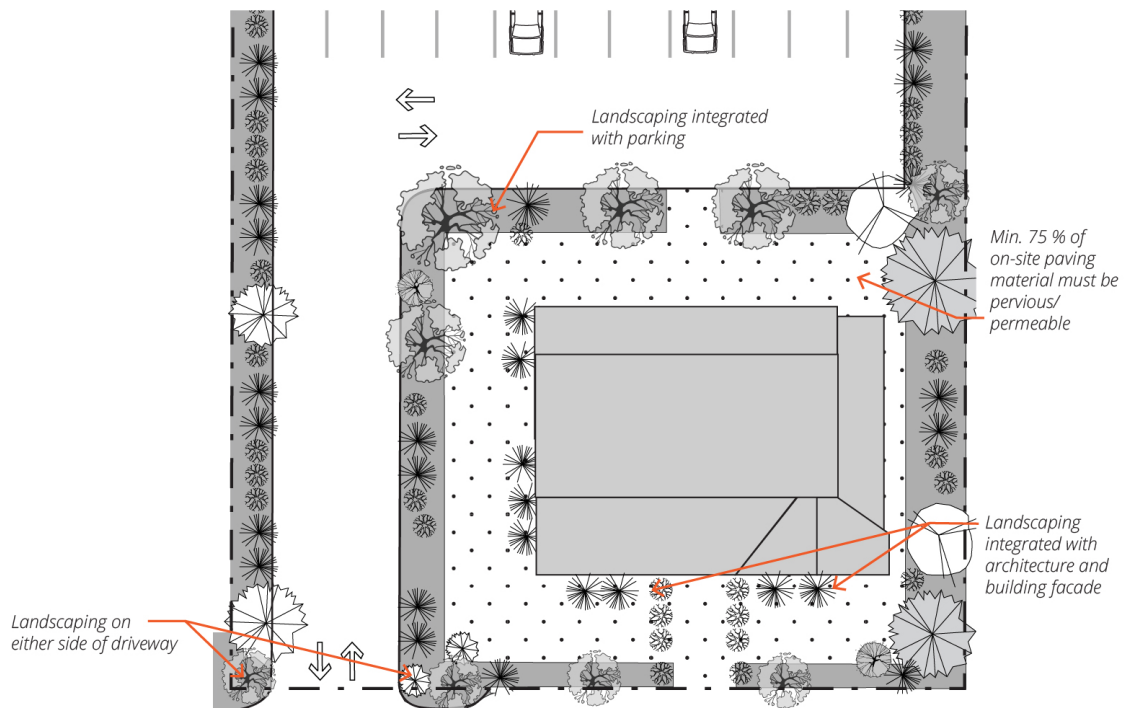

G. Parking Design and Access.

1. Where structured parking is provided, the parking area must be either:
 - a. "Lined" with ground-floor non-residential uses at least 30 feet deep as measured from the front façade; or

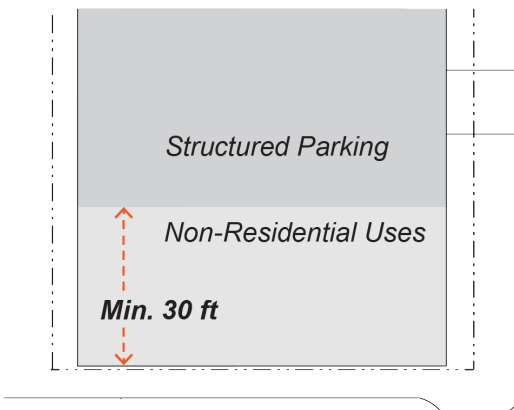

- b. Designed such that the floor elevation is a minimum 4 vertical feet below the elevation of the adjacent sidewalk.

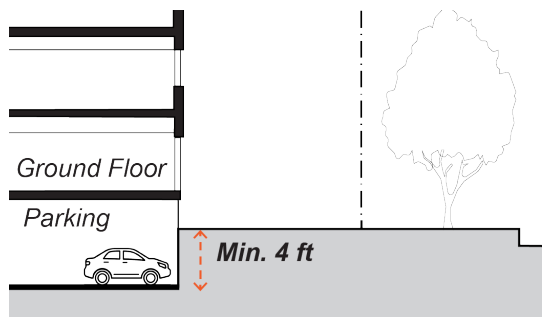

- 2. Visible structured parking must be screened from view from the right-of-way by at least one of the following features:
 - a. Regular punched openings designed to resemble windows of habitable spaces
 - b. Trellis/living wall
 - c. Custom textured or decorative screening
- 3. **Entrances to Parking Facilities.**
 - a. Curb cuts are not permitted along State Street and Main Street, except those providing direct access to parking plazas. On all other street frontages, a maximum of two curb cuts for one-way traffic and one curb cut for two-way traffic may be permitted per street frontage per lot.
 - b. Controlled entrances to parking facilities (gates, doors, etc.) shall be located a minimum 10 feet from the back of sidewalk.
 - c. Entrances to parking facilities along a street frontage shall be separated by a minimum of 40 feet, excluding access to parking plazas.
 - d. Where possible, curb cuts serving adjacent parking facilities shall be shared.

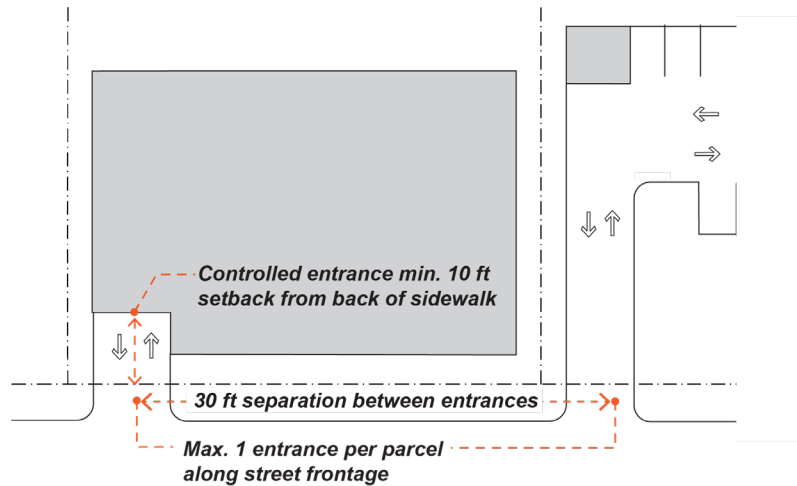

H. Site Circulation and Access

1. A clearly defined, lighted and landscaped pedestrian route shall be provided between all parking areas and primary pedestrian entrance.
2. New development on abutting lots shall be designed to allow cross-access for internal pedestrian, bicycle, and vehicular circulation systems.
3. Bicycle racks shall be provided:
 - a. In or within 50 feet of every parking area; and
 - b. Within 20 feet of at least one building entrance.

I. Service Areas and Screening.

1. Service areas must be located at the rear of lot or along a parking plaza.
2. Service areas must be enclosed in enclosures that are architecturally consistent with primary building in terms of materials, colors, and style.

J. Additional Design Standards. See Section 14.66.280 for additional design standards applicable to all residential mixed-use development in the CRS District.

Revised 14.50.170 Design Control (CT)

- A. Building Placement.** A minimum 75 percent of ground-floor building frontages facing El Camino Real must be built at the minimum setback line. This standard applies to the building frontage only (exclusive of side setbacks).
- B. Building Massing and Articulation.**
1. **Upper-story Step-backs.**
 - a. *Front:* Minimum 10 feet from ground floor façade above 45 feet in height.
 - b. *Street Side:* Minimum 10 feet from ground floor façade above 45 feet in height.
 2. **Vertical Articulation.**
 - a. When a building façade exceeds 100 feet in length along a right of way, it must be separated into primary façade bays no greater than 50 feet and secondary façade bays defined by a recess a minimum of 3 feet deep.
 - b. A minimum one entrance shall be provided per 150 linear feet along El Camino Real and per primary façade bay along all other rights-of-way.
 - c. The eave/roof of a secondary façade bay shall be no higher than the corresponding elements of the primary façade bay.

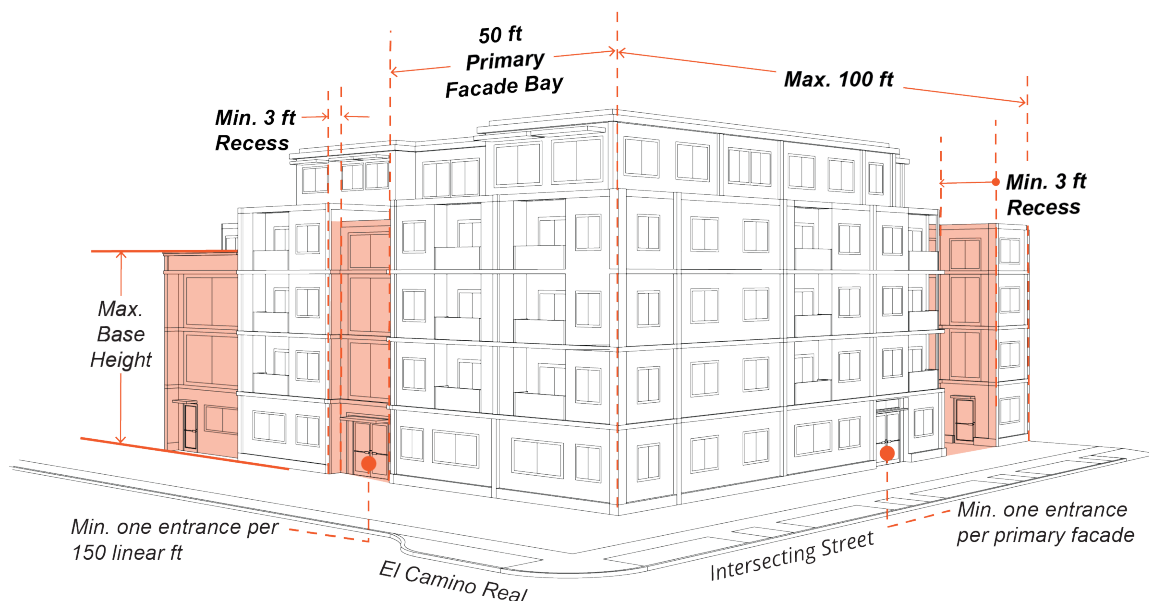

3. **Horizontal Articulation.** New facades and façade modifications along a street or civic space shall be designed to visually express a base, middle, and top.
 - a. One or more of the following patterns shall be used to define the base:
 - i. **Watertable:** Base material extends from grade to between 8 and 54 inches above grade.

- ii. Podium: The base material encompasses the lowest story (or stories) of the building, with or without mezzanine(s), and terminates in a sill, string course, or cornice at its upper bound (multi-story buildings only).
 - iii. Watertable + Cornice/String Course: A watertable using the base material is combined with a cornice or string course at the lowest story's upper bound, including any mezzanine (multi-story buildings only).
- b. The top of each building mass/bay shall be defined by elements spanning the full length of the façade of the mass/bay. Such elements may include a cornice, eave and/or gable(s), or other elements listed under Section 17.50.170.B.6. These elements shall be consistent with the overall architectural style of the building mass/bay.

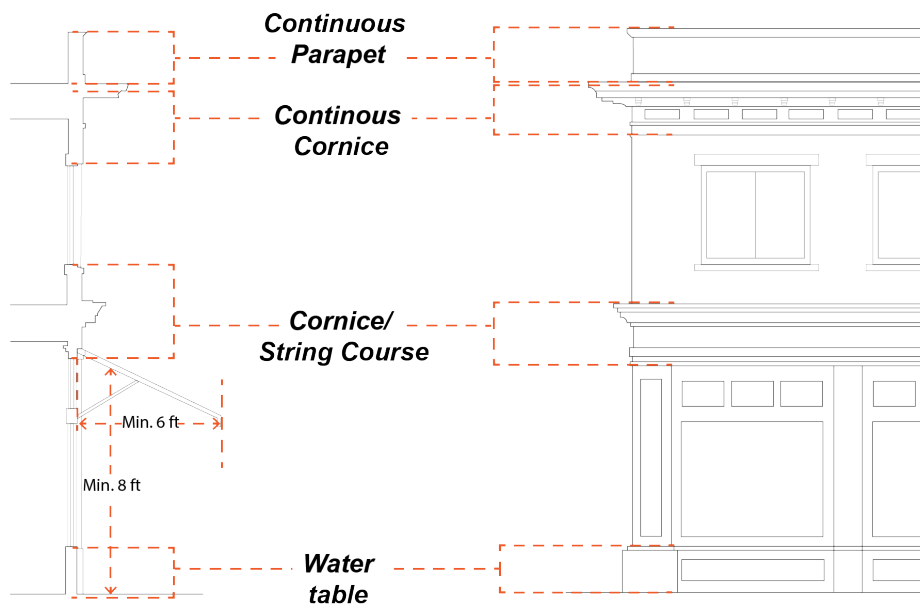
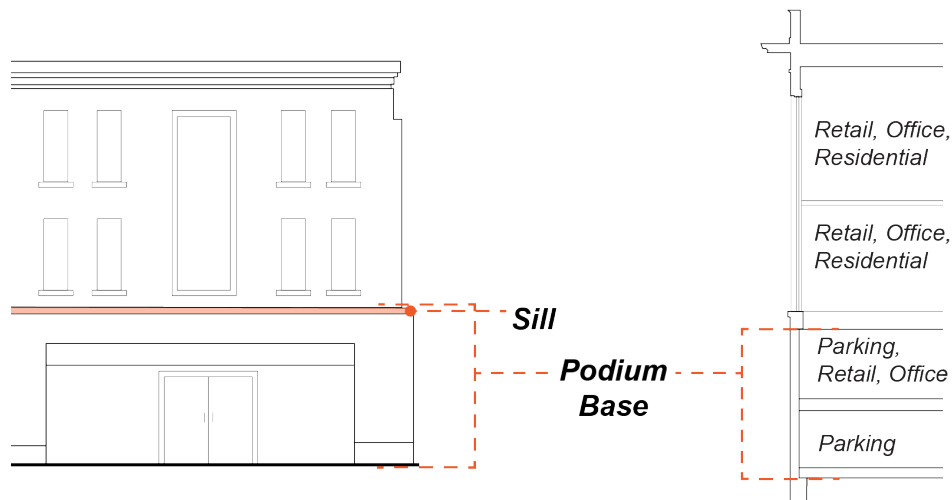

4. **Adjacencies.**

a. *Facades Adjacent to an R-1 District.*

- i. Building façade planes abutting an R-1 district may not exceed 48 feet in width.
- ii. When a building façade abutting an R-1 district exceeds 48 feet in width, it must be separated into façade bays no greater than 48 feet by a recess 10 feet wide and 15 feet deep.
- iii. Balconies, roof decks and other habitable outdoor space are not allowed on upper-story facades abutting R-1 zones.
- iv. Sliding glass doors, French doors, and floor-to-ceiling windows are not allowed on upper-story facades abutting R-1 zones.

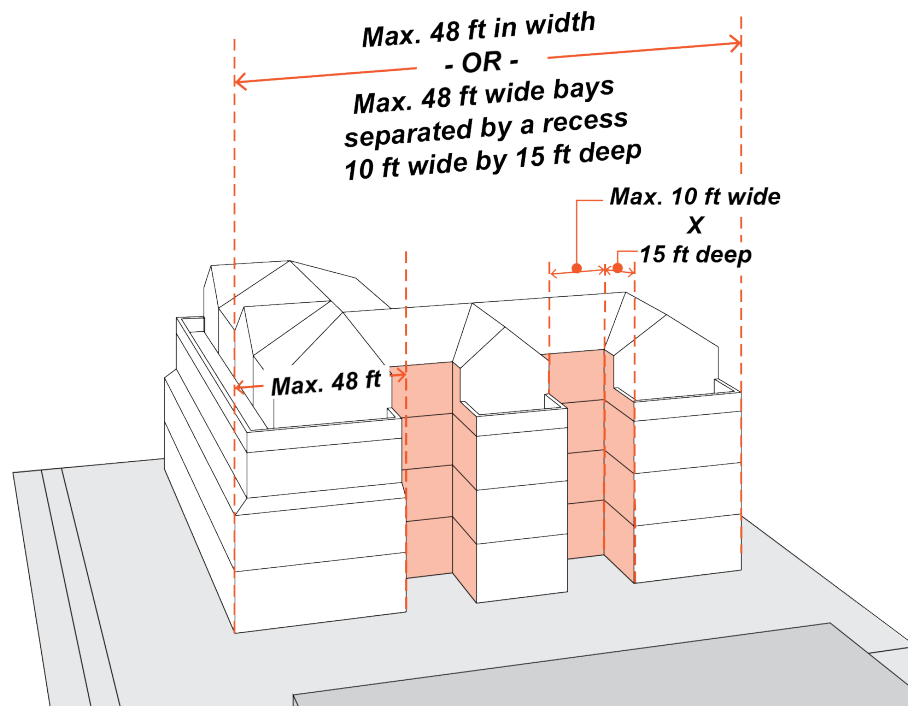

b. *Storefront Facades Adjacent to Storefront Facades.*

- i. The height of a storefront shall not differ from the height of any adjacent storefront by more than 2 feet.
- ii. The height of ground story shall not differ from height of any adjacent ground story by more than 2 feet.
- iii. Storefronts may transition in height using a module of 25 feet in length along a right-of-way.

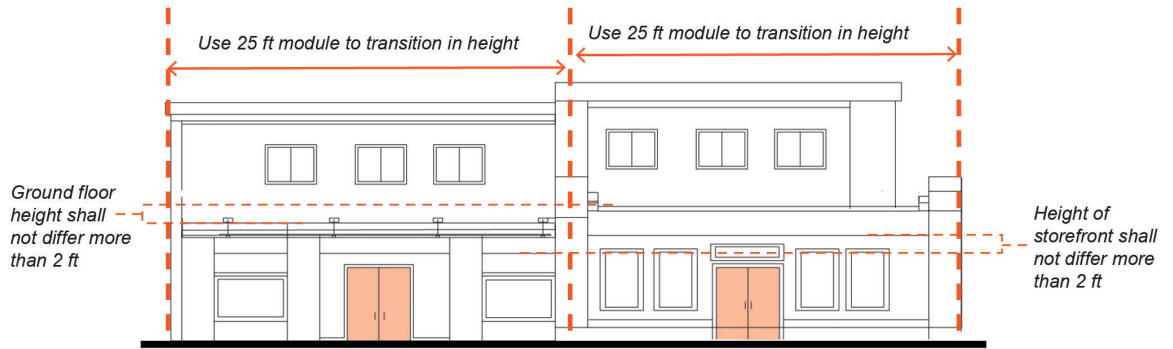

- c. **Compatibility with Adjacent Shorter Buildings with Height Difference of One Story or More.** When adjacent to an existing shorter building with a height difference of one story or more, a proposed building must utilize two or more of the following strategies:
 - i. Incorporate the uppermost floor into the roof form
 - ii. Break the mass of the building into smaller modules through changes in wall plane, setbacks, and/or height
 - iii. Match window heights and/or proportions
 - iv. Relate roof cornices and moldings at floor lines

5. **Privacy and Line of Sight.**

- a. Primary living spaces and balconies located along a side setback shall orient principal windows and balconies toward the front and rear of the building.
- b. Where windows are within 10 feet of and oriented toward an interior side setback, glazing shall either be a minimum 30-degree angle measured perpendicular to the adjacent side setback line, have minimum sill height of 42 inches, or be opaque.
- c. The maximum sill height for an ingress/egress window is 44 inches from finished floor.

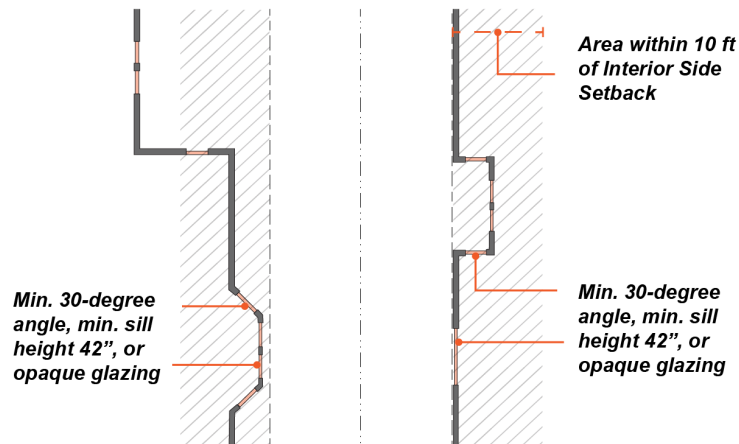

6. **Roofline and Roof Design.**

a. Roof designs shall be limited to:

- i. Hipped
- ii. Gable
- iii. Shed
- iv. Dormer
- v. Parapet.

(a) When used on the first or second floor, a parapet longer than 25 feet in length must include at least one but not more than two of the following design elements to break up the length of the parapet:

- (1) Steps
- (2) Curves
- (3) Angled surfaces

(b) The length of a parapet segment on the third floor and above may not exceed 25 feet.

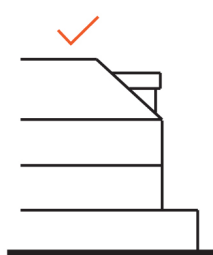

Acceptable:
Multiple stories below the story embedded in a sloped roof are also stepped-back.

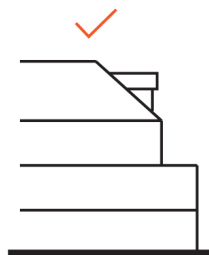

Acceptable:
One story below the story embedded in a sloped roof is also stepped-back.

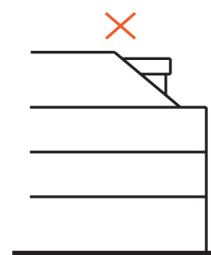

Not acceptable:
Top story embedded in a sloped roof is the only story stepped back.

- b. When the top story is stepped back and embedded in a sloped roof form, the floor below must (and other floors may) be stepped back to meet the slope of the top story.
- c. Building façades facing an R-1 district must have a hipped or gable roof and may incorporate dormers.
- d. Roofline/parapet at corners shall not exceed roofline/parapet of adjacent wallplanes by more than 24 inches.

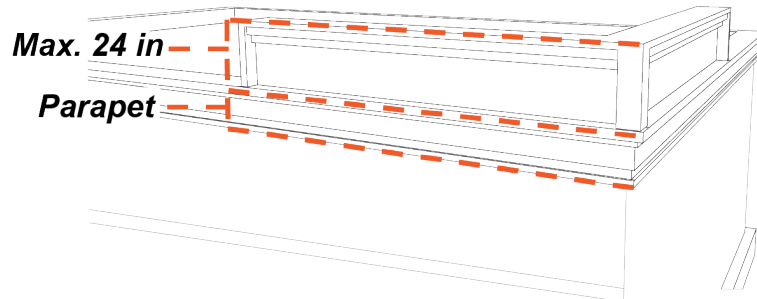

C. Building Design.

1. Façade Design.

- a. Building facades shall be arranged in an orderly composition of bays, defined by vertically aligned openings alternating horizontally with solid walls or columns. The pattern shall be visually expressed through the spacing of openings, recesses, eaves, inset panels, cornices, overhangs, trellises, exposed rafters, columns, or bay windows.
- b. The pattern may be shared between the ground floor and upper stories provided the ground floor exhibits enhanced detail or modulation.
- c. Residential facades shall incorporate at least one element that signals habitation, such as bay windows, or balconies.
- d. Non-glazed wall areas (blank walls) at the ground level must be enhanced with architectural details, landscaping, and/or landscaped trellises or lattices.

- 2. Ground Level Transparency.** A minimum 60 percent of commercial ground floor street-facing facades between 2 and 7 feet in height shall be transparent window surface. Opaque, reflective, or dark tinted glass is not allowed.

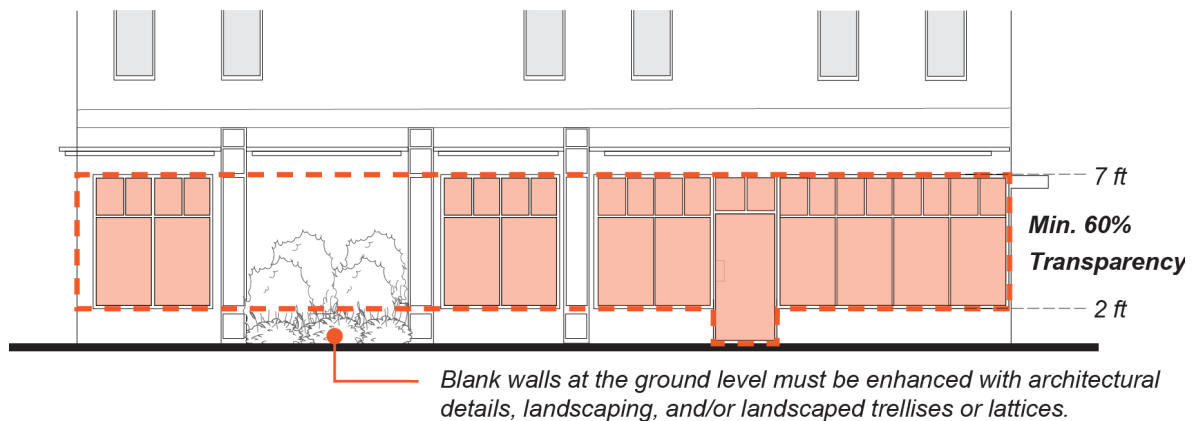

3. Pedestrian-Scaled Entrances.

- a. Buildings more than 70 feet in length along a right-of-way must incorporate at least one forecourt frontage on the right-of-way-facing façade. Required forecourts must also comply with the standards of Section 14.50.170.C.3.b.v. below.

Revised 14.50.170 Design Control (CT)

- b. Each street-facing building façade must incorporate at one of the following entry features. See Section 14.66.275 (Entrance Type Standards) for design standards applicable to each entrance type listed.
 - i. Stoop
 - ii. Shopfront
 - (a) Shopfronts more than 25 feet in width must incorporate variations in bulkhead, awnings, materials and/or color to visually articulate the shopfront into modules not to exceed 25 continuous feet.
 - iii. Gallery
 - iv. Arcade
 - v. Forecourt
 - (a) Forecourts must feature at least one entry to a shop and/or second floor use.
 - (b) The size of the forecourt must be appropriate relative to the size of the building. The maximum ratio of building height to forecourt is 2:1 (height < 2 x width).
 - (c) Forecourt must be minimum 15 feet in width.
 - (d) Forecourt must be enclosed on at least three sides by buildings.
 - (e) Forecourt must remain open to the sky (arbors and trellises are allowed).

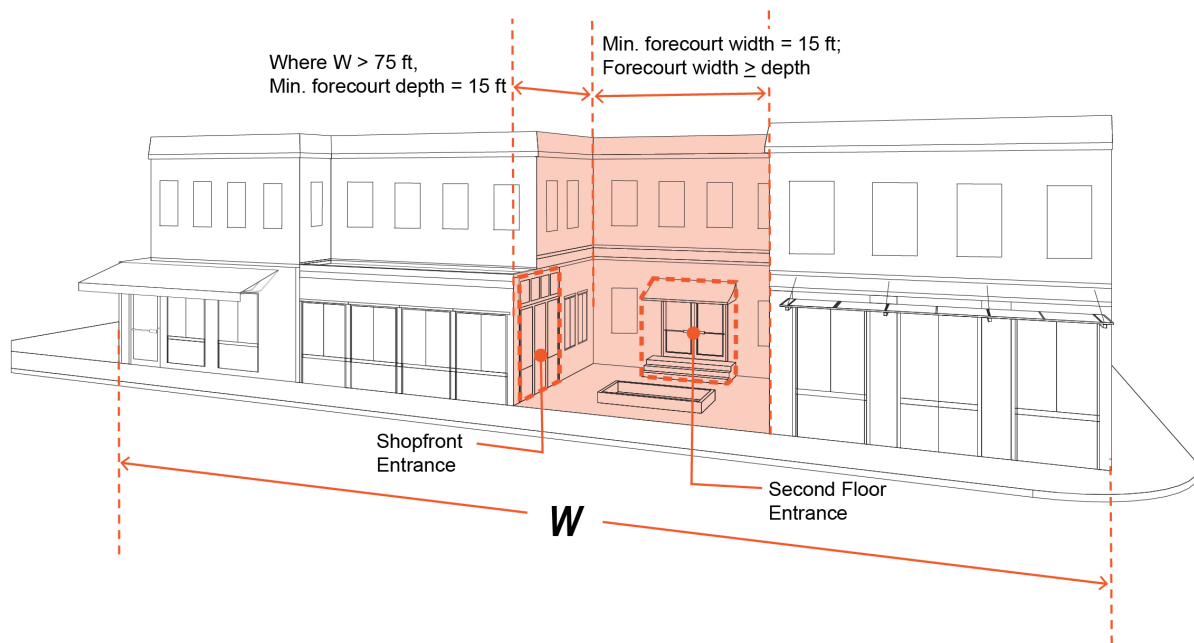

- vi. Terrace
- c. *Primary Entrance Location(s)*. Locate primary entrance on the front right-of-way.

- d. *Individual Entries.* Ground floor residential units facing a street must provide individual entries along the street frontage.
- e. *Corner Entrances.* Chamfered corners must incorporate a building entrance. Any required entrances may be provided on the corner of the building assuming one of the intersecting sides is a primary frontage.
- f. *Street-facing Entries to Upper Floors.* Street-facing entries to upper floors shall be equal in quality and detail to storefronts. This standard may be satisfied through two or more of the following:
 - i. Dedicated awning, canopy, or other roof element
 - ii. Stairs with a single color applied to treads and a contrasting color or pattern applied to risers.
 - iii. Dedicated light fixture(s)
 - iv. Decorative street address numbers or tiles
 - v. Plaque signs for upper-floor business tenants
- g. *Entry Protection.* Primary street-facing entrances shall be protected by a recess in the building frontage at least 3 feet deep or by a projection extending outward at least 3 feet measured horizontally from the entrance, and wide enough to clear the building entryway on both sides.
 - i. Protection may be coterminous with an accent element.
 - ii. Protection may take the form of an extended eave, overhang, awning, door canopy, gallery, arcade frontage, or other element that provides shade and shelter from the elements.
 - iii. The lowest edge of a projecting awning or door canopy shall have a vertical clearance of no more than 8 feet.
 - iv. Recessed entries shall differentiate pavement within the recess through the use of a dedicated paving material or pattern.

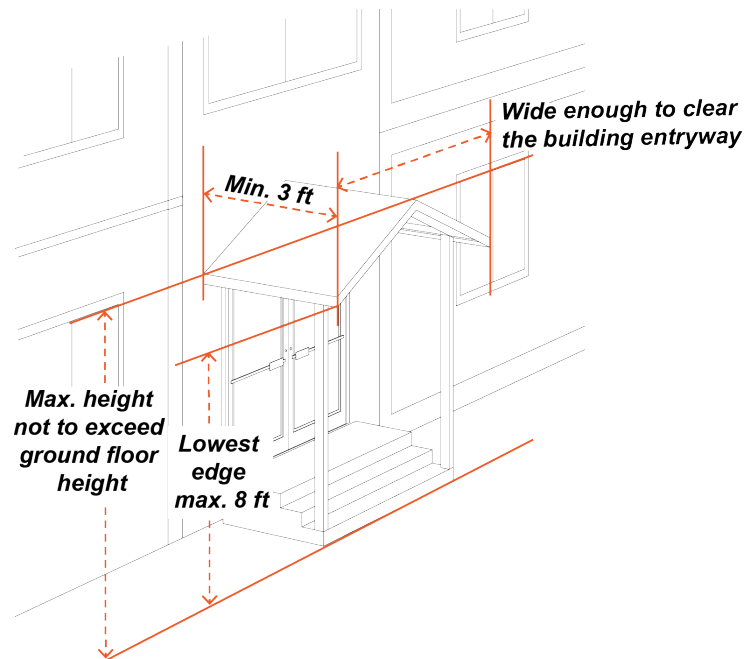

- h. Accent elements demarcating building frontage, entrance, and common open space areas shall not exceed the height of the ground floor story. Roof elements are exempted.

4. **Ground Floor Floor-to-Ceiling Height.**

- a. Minimum 24 inches taller than typical upper floor floor-to-ceiling height where ground floor is non-residential.
- b. Minimum 12 inches taller than typical upper floor floor-to-ceiling where ground floor is residential.

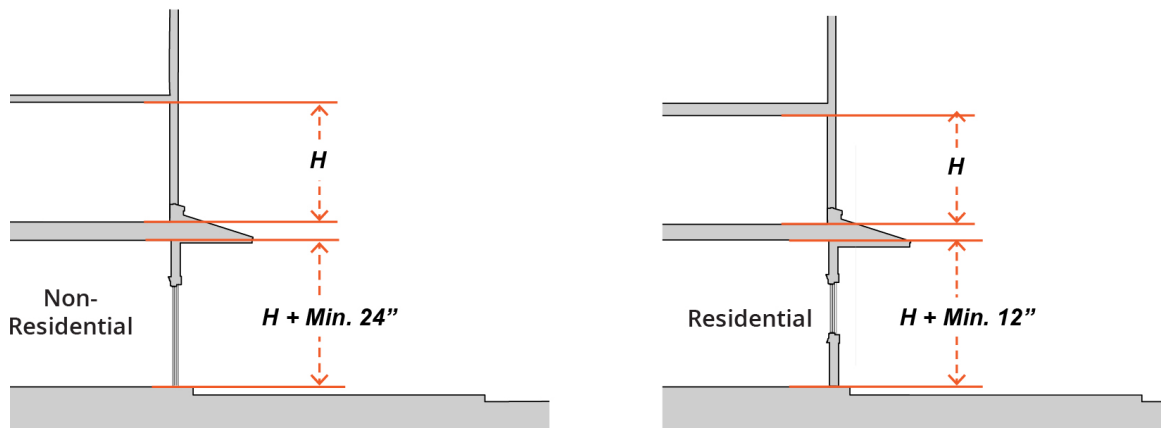

5. **Interior Courtyard.** Interior courtyards must be:

- a. Partially visible from the street and linked to the street by a clear accessible path of travel.
- b. Enclosed on at least two sides by buildings
- c. Open to the sky (arbors and trellises are allowed)

- d. A minimum width of 20 feet and a minimum area of 400 square feet.
6. **Paseos.** Paseos must be:
- a. A minimum width of 10 feet for through-block paseos.
 - b. A minimum width of 4 feet for entries to courtyards or individual single businesses.
- D. Window Design.** Vinyl windows are prohibited on facades visible from a right-of-way.
- E. Building Materials.**
1. Primary shall mean 50 percent or more of a façade surface area excluding transparent surfaces. The following primary cladding materials are allowed:
 - a. Stucco (minimum 2-coat stucco; synthetic stucco or EIFS not allowed)
 - b. Siding (lap, vertical, panelized, or shingle)
 - i. All siding shall be wood, composite wood, or cement fiberboard.
 - ii. Wood siding shall be painted or stained.
 - iii. Vinyl and aluminum siding are not permitted.
 - c. Stone
 - d. Brick
 - e. Concrete (board-form only).
 2. Secondary shall mean less than 50 percent of a façade surface area excluding transparent surfaces. The following secondary cladding materials are allowed:
 - a. Stucco (minimum 2-coat stucco; synthetic stucco not allowed, EIFS not allowed)
 - b. Siding (lap, vertical, panelized, or shingle)
 - i. All siding shall be wood, composite wood, or cement fiberboard.
 - ii. Wood siding shall be painted or stained.
 - iii. Vinyl and aluminum siding are not permitted.
 - c. Stone (building base only)
 - d. Brick (building base only)
 - e. Tile
 - f. Metal (matte finish or Cor-ten)
 - i. Ribbed metal, titanium, and mirrored finishes are not permitted.
 - g. Concrete Masonry Units (watertable and building base only, and not allowed on any façade facing a right-of-way or a single-family zone).
 - h. Concrete (building base only, board-form only, cast concrete not permitted).
 3. On attached elements, such as bay windows, orioles, and balconies.

F. Ground Level Open Space. Where any required front, rear, or side yard setback is 10 feet or greater, on-site ground-level open space shall be provided within the setback.

1. The ground level open space shall be usable and accessible.
2. The minimum dimension for ground level open space shall be 8 feet.

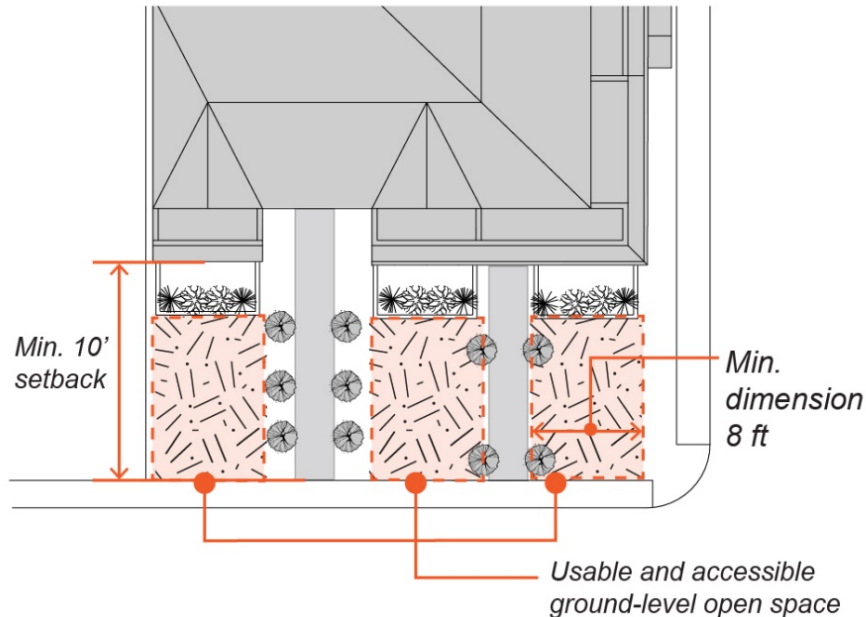

G. Landscaping and Paving.

1. Landscaping must be placed on each side of a driveway at grade or in raised planters.
2. Landscape elements shall be integrated with the building architecture, parking, and streetscape. Recommended patterns shall include, but are not limited to:
 - a. Planters for flowers and shrubs within street frontage.
 - b. Landscape buffers between parking spaces and building facades.
 - c. Landscaping within and/or on walls adjacent to courtyards, open spaces, and setbacks.
3. See Sections 14.66.180 (Maintenance of Landscaped Areas) and 14.70.070 (Landscaped Strips) for additional landscaping standards.

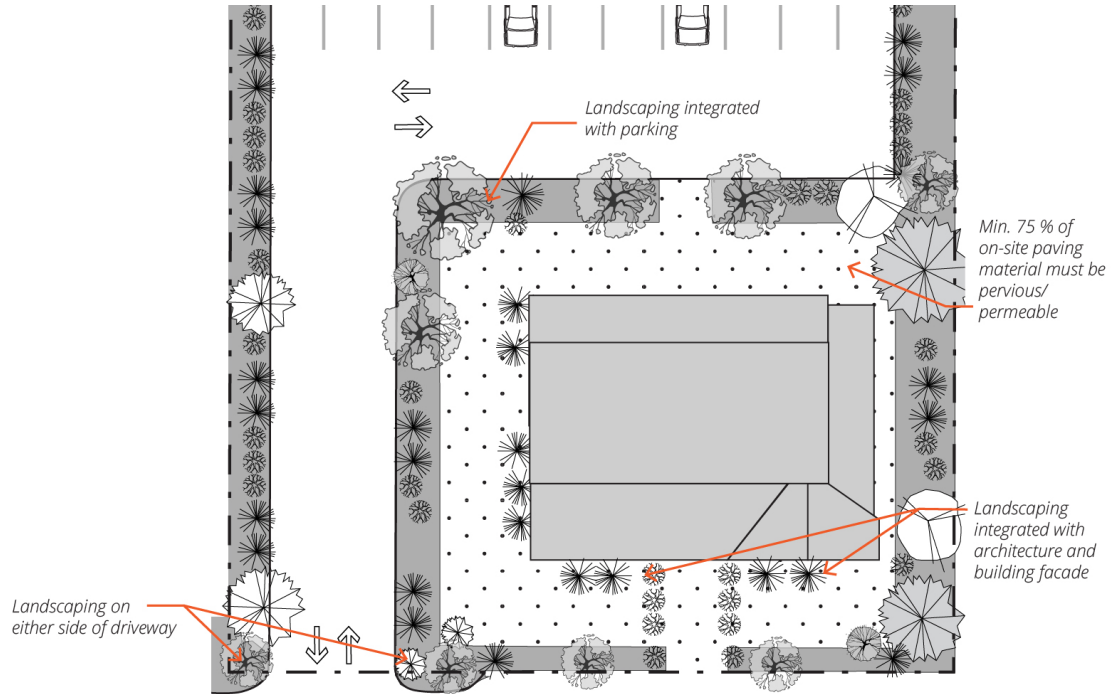

H. Parking Design and Access.

1. Where structured parking is provided, the parking area must be either:
 - a. "Lined" with ground-floor non-residential uses at least 30 feet deep as measured from the front façade; or

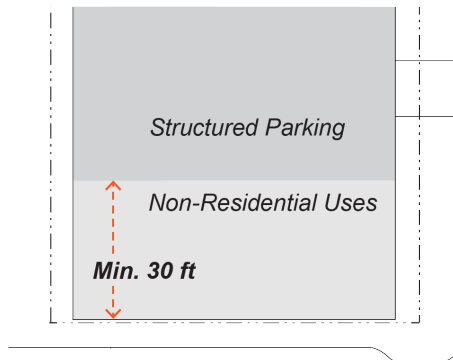

- b. Designed such that the floor elevation is a minimum 4 vertical feet below the elevation of the adjacent sidewalk.

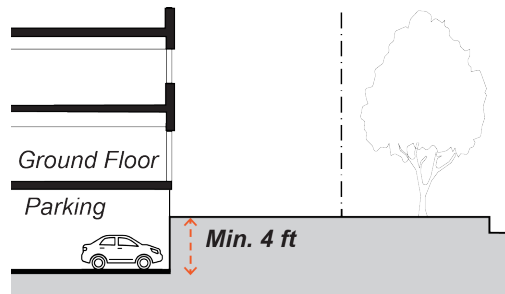

Revised 14.50.170 Design Control (CT)

2. Visible structured parking must be screened from view from the right-of-way by at least one of the following features:
 - a. Regular punched openings designed to resemble windows of habitable spaces
 - b. Trellis/living wall
 - c. Custom textured or decorative screening
3. ***Entrances to Parking Facilities.***
 - a. A maximum of two curb cuts for one-way traffic and one curb cut for two-way traffic may be permitted per street frontage per lot.
 - b. Controlled entrances to parking facilities (gates, doors, etc.) shall be located a minimum 10 feet from the back of sidewalk.
 - c. Entrances to parking facilities along a street frontage shall be separated by a minimum of 60 feet.
 - d. Where possible, curb cuts serving adjacent parking facilities shall be shared.

I. Site Circulation and Access

1. New development on abutting lots shall be designed to allow cross-access for internal pedestrian, bicycle, and vehicular circulation systems.
2. Bicycle racks shall be provided:
 - a. In or within 50 feet of every parking area; and
 - b. Within 20 feet of at least one building entrance.
3. Rear pedestrian/bicycle access shall be provided from any abutting right-of-way or alley for projects on:
 - a. Lots with a depth of 250 feet or greater; and
 - b. Lots where development abuts an R-1 district to the rear.

J. Service Areas and Screening.

1. Service areas must be located at the rear of lot.
2. Service areas must be enclosed in enclosures that are architecturally consistent with primary building in terms of materials, colors, and style.

K. Additional Design Standards. See Section 14.66.280 for additional design standards applicable to all residential mixed-use development in the CT District.

Revised 14.52.110 Design Control (CD/R3)

A. Building Massing and Articulation.

1. Upper-story Step-backs

- a. *Front:* Minimum 10 feet from ground floor façade above 30 feet in height (commercial or mixed use) or 35 feet (residential only).
- b. *Street Side:* Minimum 10 feet from ground floor façade above 30 feet in height (commercial or mixed use) or 35 feet (residential only).
- c. For buildings over three stories, the uppermost story must be embedded in a sloped roof form such as a mansard roof or a hipped and/or gabled roof with dormers, as allowed by standards in Section 14.52.110.A.6.

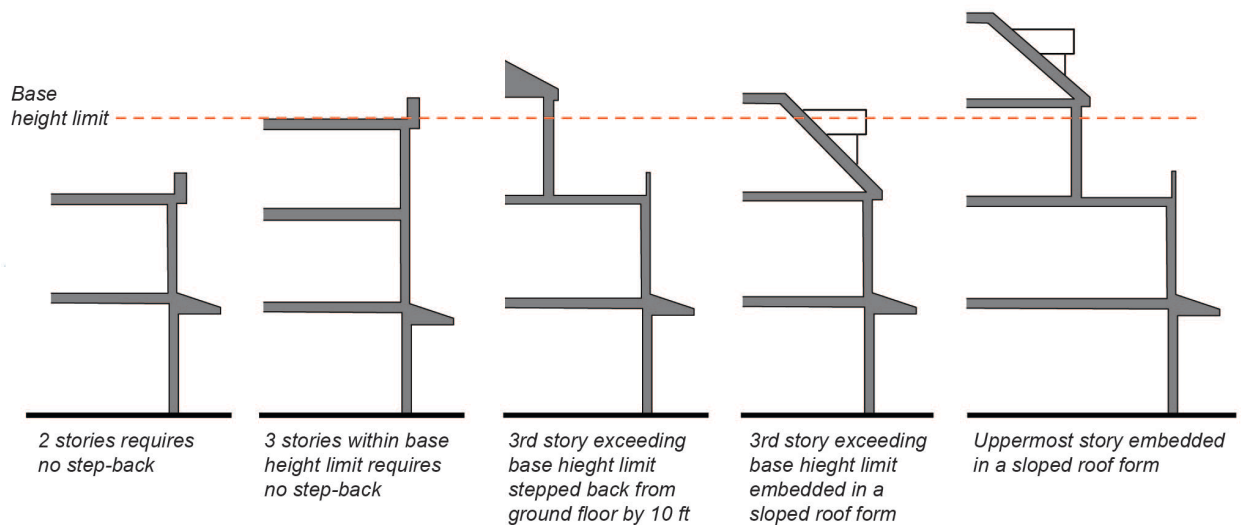

2. Vertical Articulation.

- a. When a building façade exceeds 75 feet in length along a right of way, it must be separated into primary façade bays no greater than 50 feet and secondary façade bays defined by a recess a minimum of 3 feet deep.
- b. The building shall include at least one ground-floor entrance every 25 feet.
- c. The eave/roof of a secondary façade bay shall be no higher than the corresponding elements of the primary façade bay.

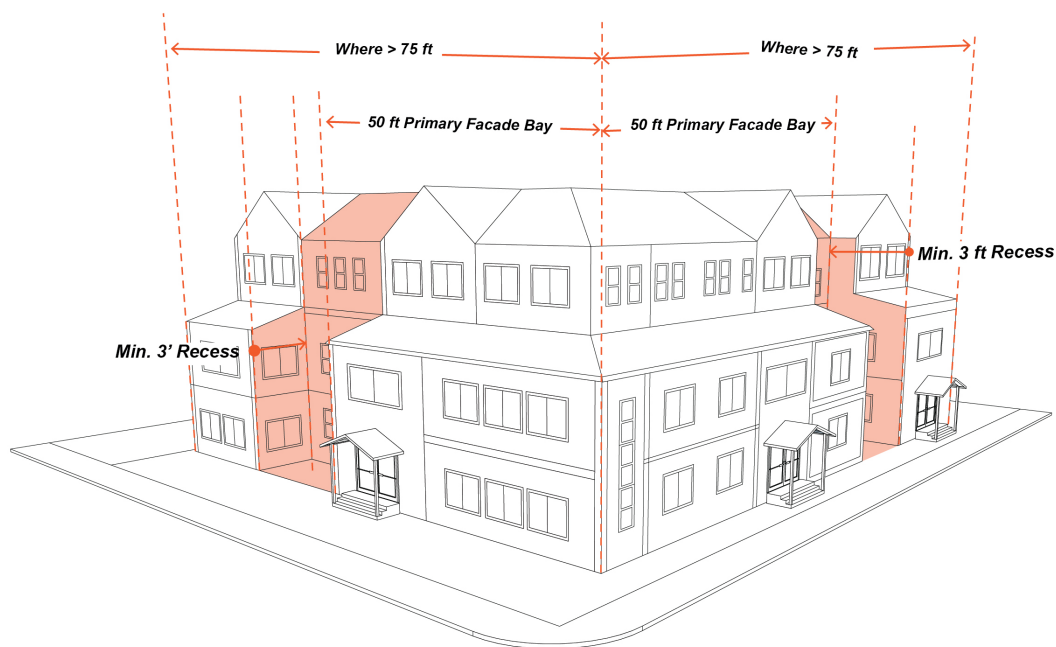

3. **Horizontal Articulation.** New facades and façade modifications along a street or civic space shall be designed to visually express a base, middle, and top.
 - a. One or more of the following patterns shall be used to define the base:
 - i. Watertable: Base material extends from grade to between 8 and 54 inches above grade.
 - ii. Podium: The base material encompasses the lowest story (or stories) of the building, with or without mezzanine(s), and terminates in a sill, string course, or cornice at its upper bound (multi-story buildings only).
 - iii. Watertable + Cornice/String Course: A watertable using the base material is combined with a cornice or string course at the lowest story's upper bound, including any mezzanine (multi-story buildings only).
 - b. The top of each building mass/bay shall be defined by elements spanning the full length of the façade of the mass/bay. Such elements may include a cornice, eave and/or gable(s), or other elements listed under Section 17.52.110.A.6. These elements shall be consistent with the overall architectural style of the building mass/bay.

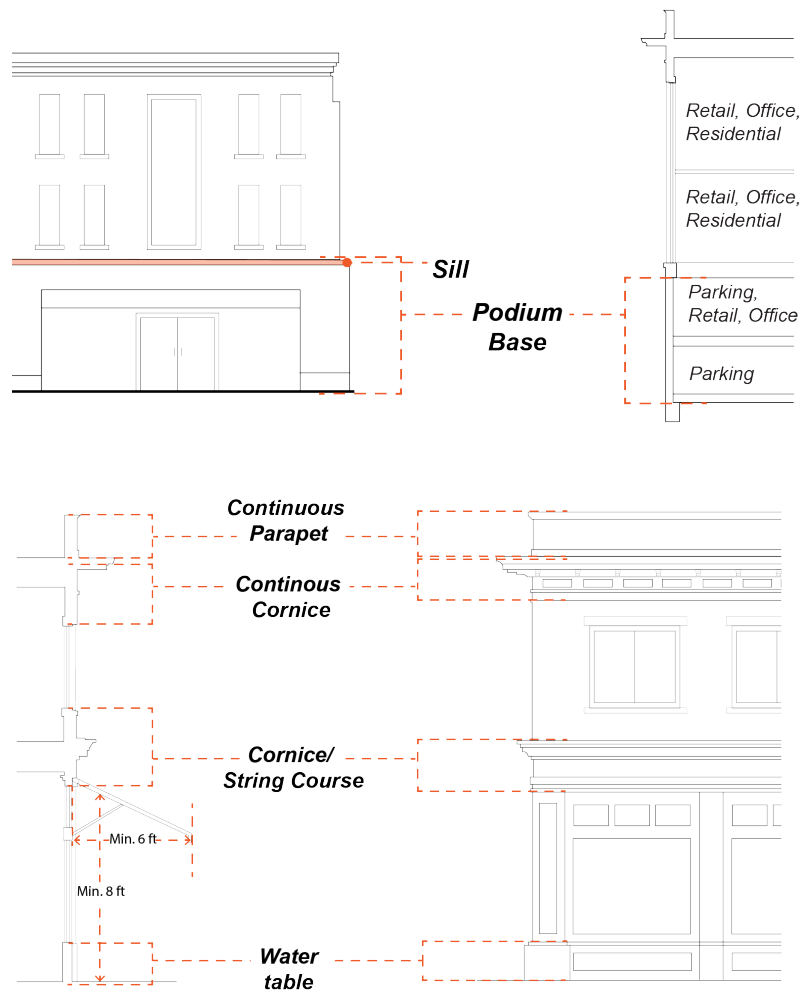

4. **Adjacencies.**

a. *Storefront Facades Adjacent to Storefront Facades.*

- i. The height of a storefront shall not differ from the height of any adjacent storefront by more than 2 feet.
- ii. The height of ground story shall not differ from height of any adjacent ground story by more than 2 feet.
- iii. Storefronts may transition in height using a module of 25 feet in length along a right-of-way.

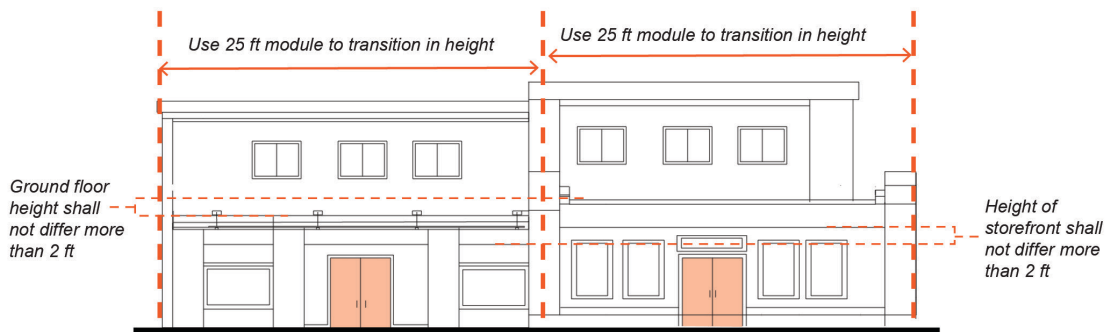

- b. **Compatibility with Adjacent Shorter Buildings with Height Difference of One Story or More.** When adjacent to an existing shorter building with a height difference of one story or more, a proposed building must utilize two or more of the following strategies:
 - i. Incorporate the uppermost floor into the roof form
 - ii. Break the mass of the building into smaller modules through changes in wall plane, setbacks, and/or height
 - iii. Match window heights and/or proportions
 - iv. Relate roof cornices and moldings at floor lines

5. **Privacy and Line of Sight.**

- a. Primary living spaces and balconies located along a side setback shall orient principal windows and balconies toward the front and rear of the building.
- b. Where windows are within 10 feet of and oriented toward an interior side setback, glazing shall either be a minimum 30-degree angle measured perpendicular to the adjacent side setback line, have minimum sill height of 42 inches, or be opaque.
- c. The maximum sill height for an ingress/egress window is 44 inches from finished floor.

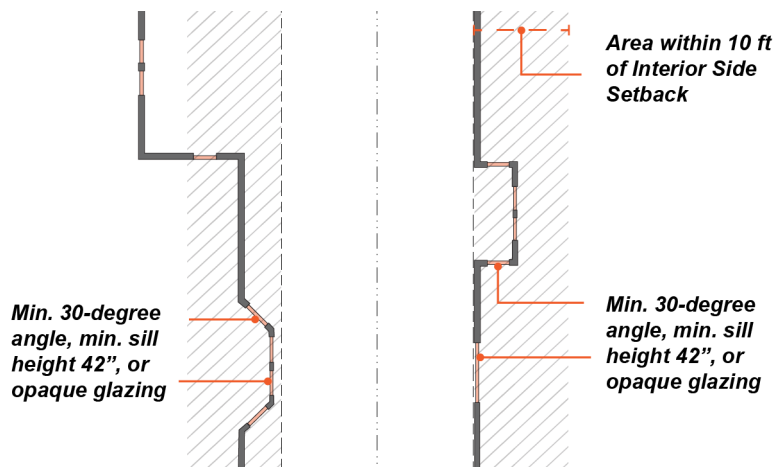

6. **Roofline and Roof Design.**

- a. Roof designs shall be limited to:
 - i. Hipped
 - ii. Gable
 - iii. Mansard
 - (a) Applicable for buildings 3 or more stories.
 - iv. Dormer
 - v. Parapet.
 - (a) Allowed only along First Street frontages.
 - (b) When used on the first or second floor, a parapet longer than 25 feet in length must include at least one but not more than two of the following design elements to break up the length of the parapet:
 - (1) Steps
 - (2) Curves
 - (3) Angled surfaces
 - (c) The length of a parapet segment on the third floor and above may not exceed 25 feet.
- b. When the top story is stepped back and embedded in a sloped roof form such as a mansard roof or a hipped and/or gabled roof with dormers, the floor below must (and other floors may) be stepped back to meet the slope of the top story.

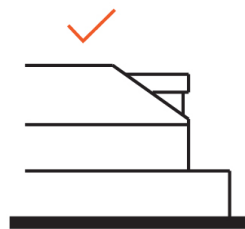

Acceptable:
One story below the story embedded in a sloped roof is also stepped-back .

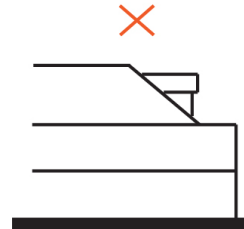

Not acceptable:
Top story embedded in a sloped roof is the only story stepped back.

- c. Building façades facing an R-1 district must have a hipped or gable roof and may incorporate dormers.
- d. Roofline/parapet at corners shall not exceed roofline/parapet of adjacent wallplanes by more than 24 inches.

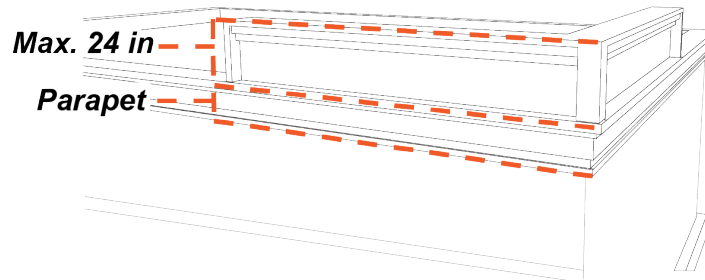

B. Building Design.

1. Façade Design.

- a. Building facades must continue the pattern established by existing buildings in Downtown Los Altos by reinforcing the underlying maximum 50-foot module along all street frontages through the use of the following techniques:
 - i. Building facades shall be arranged in an orderly composition of bays, defined by vertically aligned openings alternating horizontally with solid walls or columns. The pattern shall be visually expressed through the spacing of openings, recesses, eaves, inset panels, cornices, overhangs, trellises, exposed rafters, columns, or bay windows.
 - ii. The pattern may be shared between the ground floor and upper stories provided the ground floor exhibits enhanced detail or modulation.
 - iii. Residential facades shall incorporate at least one element that signals habitation, such as bay windows, or balconies.
 - iv. Non-glazed wall areas (blank walls) at the ground level must be enhanced with architectural details, landscaping, and/or landscaped trellises or lattices.
- b. At least two of the following strategies must be used in a manner that reinforces the maximum 50-foot module:
 - i. Change in roof parapet height or shape.
 - ii. Change in roof style
 - iii. Change in materials palette
 - iv. Change in building height, minimum 8-foot difference.
 - v. Change in frontage type or change in details of Shopfront frontage type if used.
 - vi. Use of upper floor projections such as bay windows or balconies.

2. Pedestrian-Scaled Entrances.

- a. Buildings more than 75 feet in frontage length along a right-of-way and First Street must incorporate at least one forecourt with a minimum depth of 20 feet from front façade. Required forecourts must also comply with the standards of Section 14.52.110.B.2.b.vi. below.

- b. Building entrances must incorporate at least one of the following entry features. See Section 14.66.275 (Entrance Type Standards) for design standards applicable to each entrance type listed.
 - i. Stoop
 - ii. Dooryard
 - iii. Shopfront
 - (a) The maximum width of single shopfront shall be 25 feet.
 - iv. Gallery
 - v. Arcade
 - vi. Forecourt
 - (a) Forecourts must feature at least one entry to a shop and/or second floor use.
 - (b) Forecourts for buildings more than 70 feet in length along a right-of-way must have a minimum width and depth of 15 feet from front façade. Width of forecourt shall be equal to or greater than depth.
 - (c) The size of the forecourt must be appropriate relative to the size of the building. The maximum ratio of building height to forecourt is 2:1 (height < 2 x width).
 - (d) Forecourt must be enclosed on at least three sides by buildings.
 - (e) Forecourt must remain open to the sky (arbors and trellises are allowed).

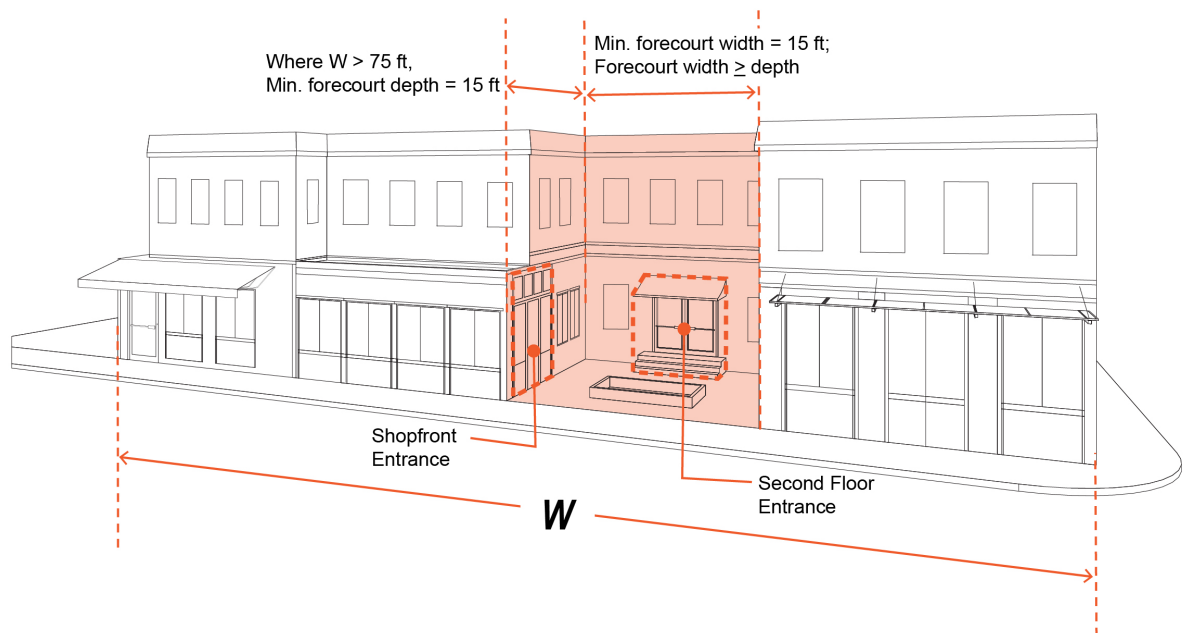

- vii. Terrace

- c. *Primary Entrance Location(s)*. Locate primary entrance on the front right-of-way and/or in the interior courtyard.
- d. *Individual Entries*. Ground floor residential units facing a street must provide individual entries along the street frontage.
- e. *Corner Entrances*. Chamfered corners must incorporate a building entrance. Any required entrances may be provided on the corner of the building assuming one of the intersecting sides is a primary frontage.
- f. *Street-facing Entries to Upper Floors*. Street-facing entries to upper floors shall be equal in quality and detail to storefronts. This standard may be satisfied through two or more of the following:
 - i. Dedicated awning, canopy, or other roof element
 - ii. Stairs with a single color applied to treads and a contrasting color or pattern applied to risers.
 - iii. Dedicated light fixture(s)
 - iv. Decorative street address numbers or tiles
 - v. Plaque signs for upper-floor business tenants
- g. *Entry Protection*. Primary street-facing entrances shall be protected by a recess in the building frontage at least 3 feet deep or by a projection extending outward at least 3 feet measured horizontally from the entrance, and wide enough to clear the building entryway on both sides.
 - i. Protection may be coterminous with an accent element.
 - ii. Protection may take the form of an extended eave, overhang, awning, door canopy, gallery, arcade frontage, or other element that provides shade and shelter from the elements.
 - iii. The lowest edge of a projecting awning or door canopy shall have a vertical clearance of no more than 8 feet.
 - iv. Recessed entries shall differentiate pavement within the recess through the use of a dedicated paving material or pattern.

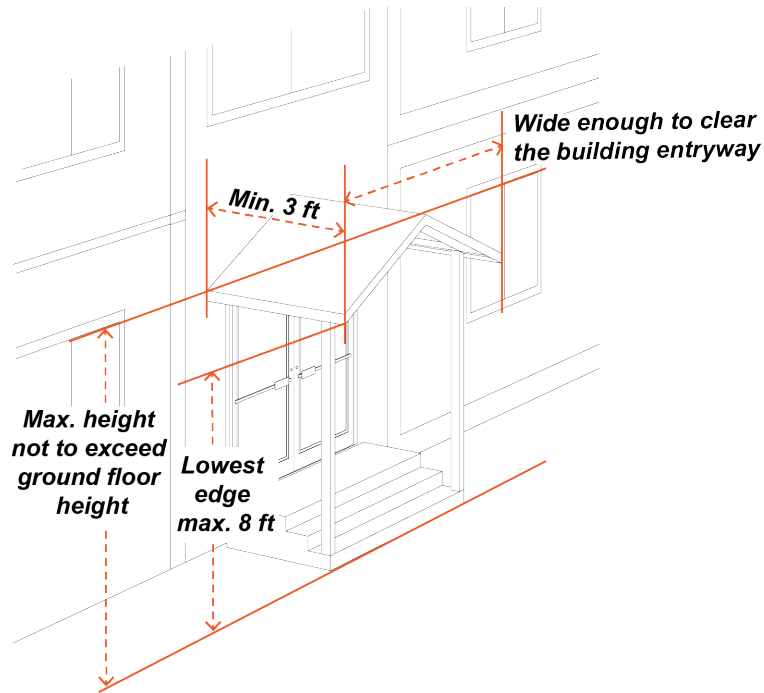

- h. Accent elements demarcating building frontage, entrance, and common open space areas shall not exceed the height of the ground floor story. Roof elements are excepted.

3. **Ground Floor Floor-to-Ceiling Height.**

- a. Minimum 24 inches taller than typical upper floor floor-to-ceiling height where ground floor is non-residential.
- b. Minimum 12 inches taller than typical upper floor floor-to-ceiling where ground floor is residential.

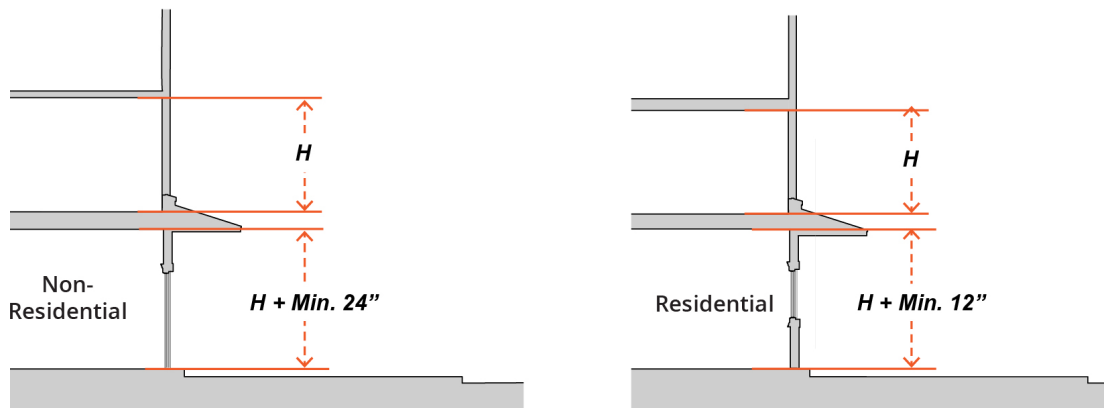

4. **Interior Courtyard.** Interior courtyards must be:

- a. Partially visible from the street and linked to the street by a clear accessible path of travel.
- b. Enclosed on at least two sides by buildings.

- c. Open to the sky (arbors and trellises are allowed).
 - d. A minimum width of 20 feet and a minimum area of 400 square feet.
5. **Paseos.** Paseos must be:
- a. A minimum width of 10 feet for through-block paseos.
 - b. A minimum width of 4 feet for entries to courtyards or individual single businesses.

C. Window Design.

- 1. Window frames, backbands, and sills.
 - a. All windows shall have a sill.
 - i. The sill shall extend horizontally beyond the window opening or frame/casing (if present) at each end.
 - ii. The sill shall be sloped toward the outside.
 - iii. The sill shall have a drip at its outer edge.
- 2. Vinyl windows are prohibited on facades visible from a right-of-way.

D. Building Materials.

- 1. Primary shall mean 50 percent or more of a façade surface area excluding transparent surfaces. The following primary cladding materials are allowed:
 - a. Stucco (minimum 2-coat stucco; synthetic stucco or EIFS not allowed)
 - b. Siding (lap, vertical, panelized, or shingle)
 - i. All siding shall be wood, composite wood, or cement fiberboard.
 - ii. Wood siding shall be painted or stained.
 - iii. Vinyl and aluminum siding are not permitted.
 - c. Stone
 - d. Brick
- 2. Secondary shall mean less than 50 percent of a façade surface area excluding transparent surfaces. The following secondary cladding materials are allowed:
 - a. Stucco (minimum 2-coat stucco; synthetic stucco not allowed, EIFS not allowed)
 - b. Siding (lap, vertical, panelized, or shingle)
 - i. All siding shall be wood, composite wood, or cement fiberboard.
 - ii. Wood siding shall be painted or stained.
 - iii. Vinyl and aluminum siding are not permitted.
 - c. Stone (building base only)
 - d. Brick (building base only)

- e. Tile
- f. Metal (matte finish or Cor-ten)
 - i. Ribbed metal, titanium, and mirrored finishes are not permitted.
- g. Concrete Masonry Units (watertable and building base only, and not allowed on any façade facing a right-of-way or a single-family zone).
- h. Concrete (building base only, board-form only, cast concrete not permitted).

E. Downtown Gateways. Downtown gateways are located at the intersection of Foothill Expressway and Edith Avenue and the intersection of Foothill Expressway and San Antonio Road.

- 1. Building design at gateway intersection shall include:
 - a. Façade lighting; and
 - b. Overhangs or sloped roof forms.
- 2. Ground-floor design at gateway intersections must address both street frontages through:
 - a. Entrances that are visible and directly accessible from both streets;
 - b. Building transparency beyond the required minimum for the first 15 feet of building frontage from the corner;
 - c. Landscaped area with a minimum dimension of six feet; and
 - d. A usable public space with pedestrian-scaled features.

F. Landscaping and Paving.

- 1. Landscaping must be placed on each side of a driveway at grade or in raised planters.
- 2. All paving located adjacent to a sidewalk must be textured (decorative or permeable).
- 3. A minimum 75 percent of on-site paving material must be pervious or permeable.
- 4. Landscape elements shall be integrated with the building architecture, parking, and streetscape. Recommended patterns shall include, but are not limited to:
 - a. Planters for flowers and shrubs within street frontage.
 - b. Landscape buffers between parking spaces and building facades.
 - c. Landscaping within and/or on walls adjacent to courtyards, open spaces, and setbacks.
- 5. See Sections 14.66.180 (Maintenance of Landscaped Areas) and 14.70.070 (Landscaped Strips) for additional landscaping standards.

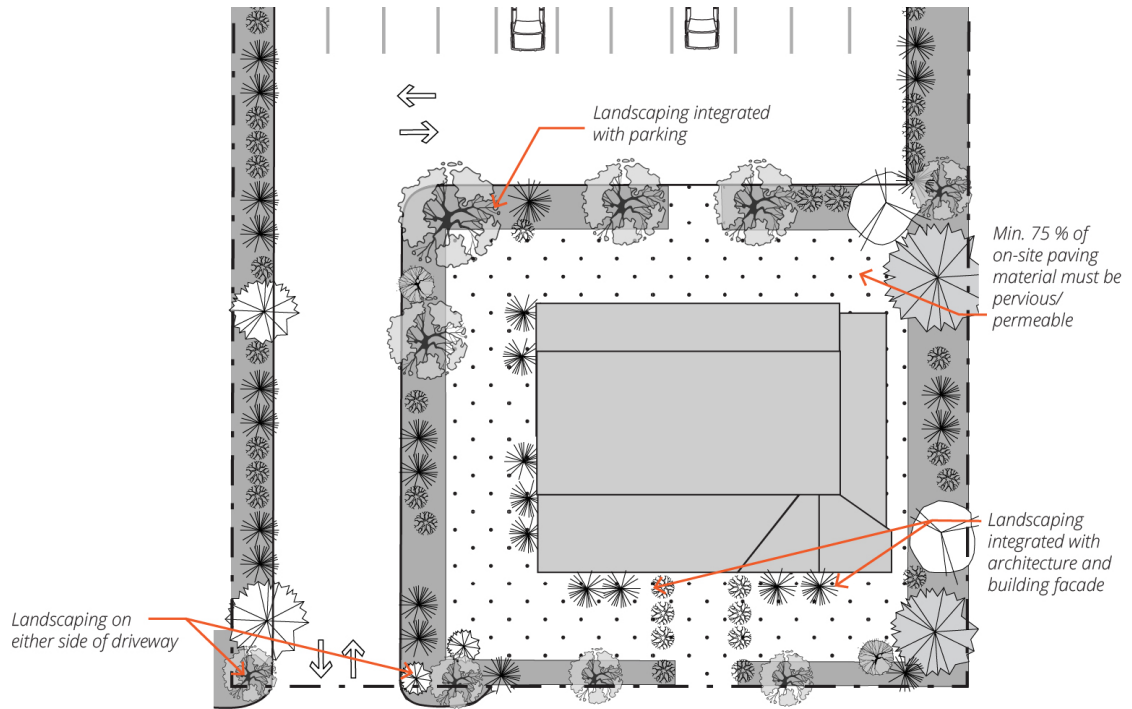

- G. Ground Level Open Space.** The required front setback area for residential-only development must be improved with a usable open space a minimum of 7 feet in depth for a minimum 50 percent of the building frontage.

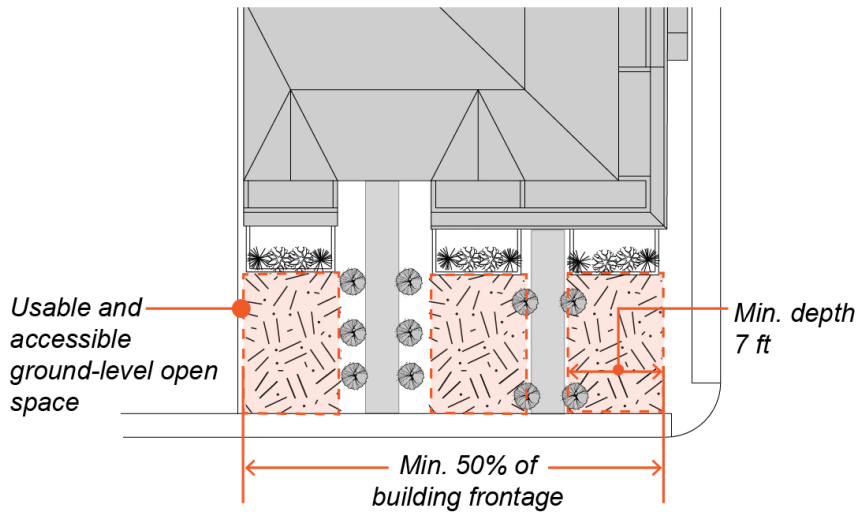

H. Parking Design and Access.

1. Where structured parking is provided, the parking area must be either:
 - a. "Lined" with ground floor non-residential uses at least 30 feet deep as measured from the front façade; or

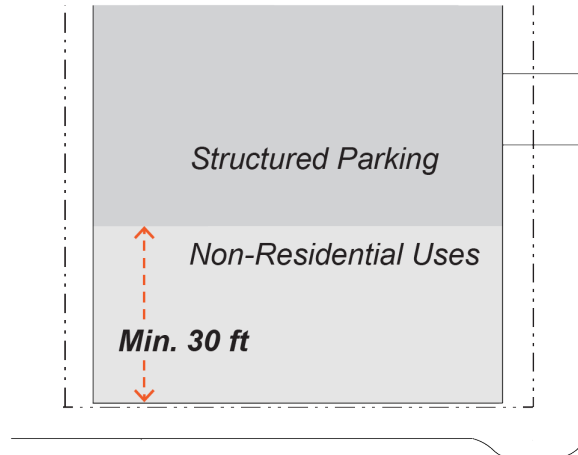

- b. Designed such that the floor elevation is a minimum 4 vertical feet below the elevation of the adjacent sidewalk.

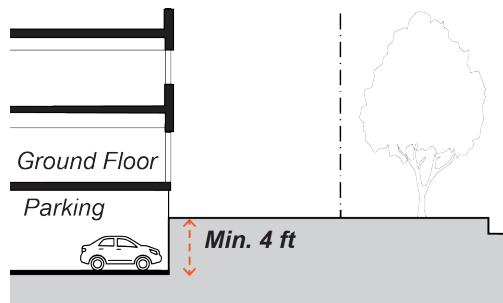

- 2. Visible structured parking must be screened from view from the right-of-way by at least one of the following features:
 - a. Regular punched openings designed to resemble windows of habitable spaces
 - b. Trellis/living wall
 - c. Custom textured or decorative screening
- 3. **Entrances to Parking Facilities.**
 - a. A maximum of two curb cuts for one-way traffic and one curb cut for two-way traffic may be permitted per street frontage per lot.
 - b. Controlled entrances to parking facilities (gates, doors, etc.) shall be located a minimum 10 feet from the back of sidewalk.
 - c. Entrances to parking facilities along a street frontage shall be separated by a minimum of 30 feet.
 - d. Where possible, curb cuts serving adjacent parking facilities shall be shared.

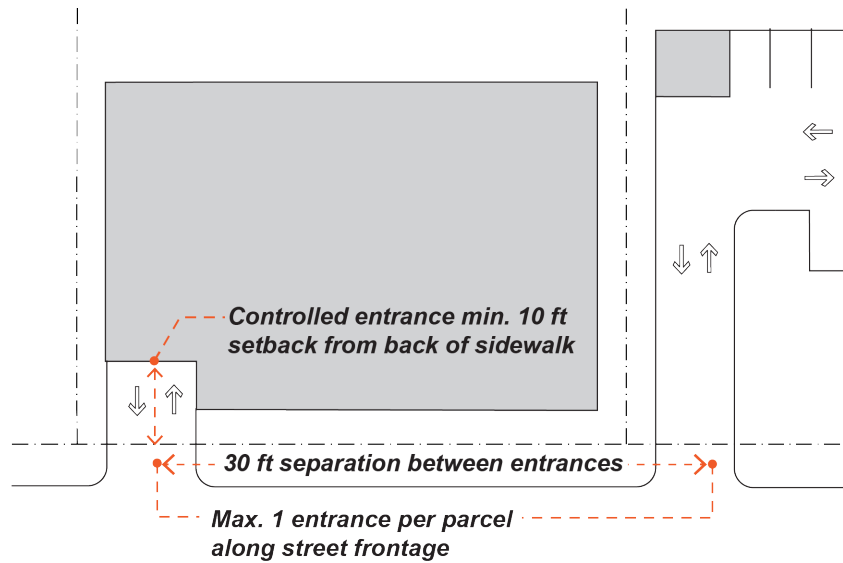

I. Site Circulation and Access.

1. A clearly defined, lighted and landscaped pedestrian route shall be provided between all parking areas and primary pedestrian entrance.
2. New development on abutting lots shall be designed to allow cross-access for internal pedestrian, bicycle, and vehicular circulation systems.
3. Bicycle racks shall be provided:
 - a. In or within 50 feet of every parking area; and
 - b. Within 20 feet of at least one building entrance.

J. Service Areas and Screening.

1. Service areas must be located at the rear of lot or along a parking plaza.
2. Service areas must be enclosed in enclosures that are architecturally consistent with primary building in terms of materials, colors, and style.

K. Additional Design Standards. See Section 14.66.280 for additional design standards applicable to all residential mixed-use development in the CD/R3 District.

Revised 14.54.130 Design Control (CRS/OAD)

A. Building Massing and Articulation.

1. *Upper-story Step-backs, Front and Street Side.*

- a. The third story must be either stepped back a minimum 5 feet from the ground floor façade or embedded in a sloped roof form such as a mansard roof or a hipped and/or gabled roof with dormers, as allowed by standards in Section 14.54.130.A.6.
- b. For buildings over three stories, the uppermost story must be embedded in a sloped roof form such as a mansard roof or a hipped and/or gabled roof with dormers, as allowed by standards in Section 14.54.130.A.6.

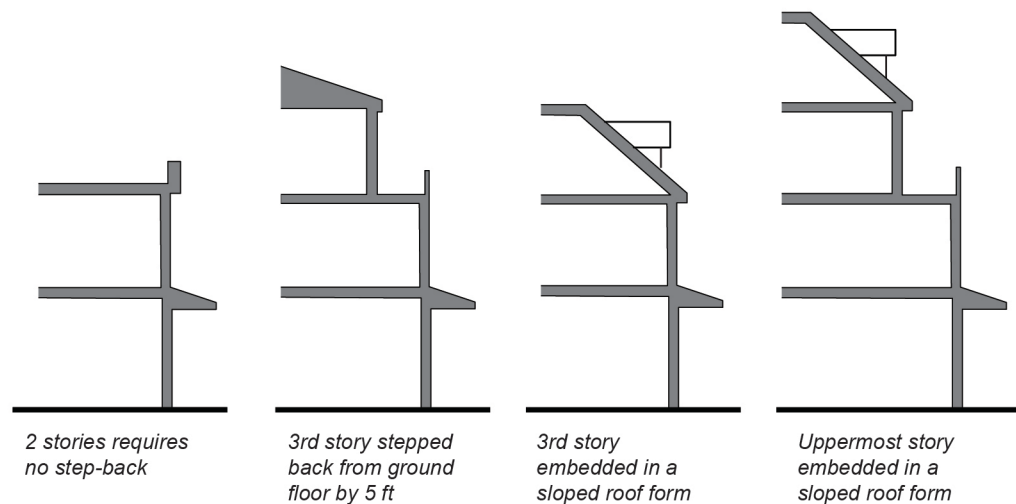

2. *Vertical Articulation.*

- a. When a building façade exceeds 50 feet in length along a right of way, it must be separated into primary façade bays no greater than 50 feet and secondary façade bays defined by a recess a minimum of 3 feet deep.
- b. A minimum one entrance shall be provided per primary façade bay.
- c. The eave/roof of a secondary façade bay shall be no higher than the corresponding elements of the primary façade bay.

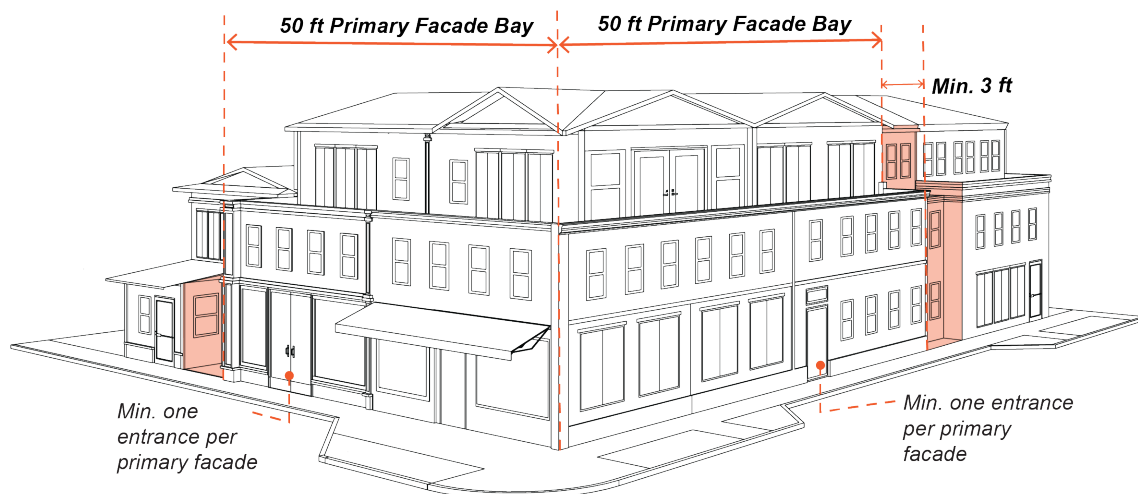

3. **Horizontal Articulation.** New facades and façade modifications along a street or civic space shall be designed to visually express a base, middle, and top.
 - a. One or more of the following patterns shall be used to define the base:
 - i. Watertable: Base material extends from grade to between 8 and 54 inches above grade.
 - ii. Podium: The base material encompasses the lowest story (or stories) of the building, with or without mezzanine(s), and terminates in a sill, string course, or cornice at its upper bound (multi-story buildings only).
 - iii. Watertable + Cornice/String Course: A watertable using the base material is combined with a cornice or string course at the lowest story's upper bound, including any mezzanine (multi-story buildings only).
 - b. The top of each building mass/bay shall be defined by elements spanning the full length of the façade of the mass/bay. Such elements may include a cornice, eave and/or gable(s), or other elements listed under Section 17.54.130.A.6. These elements shall be consistent with the overall architectural style of the building mass/bay.

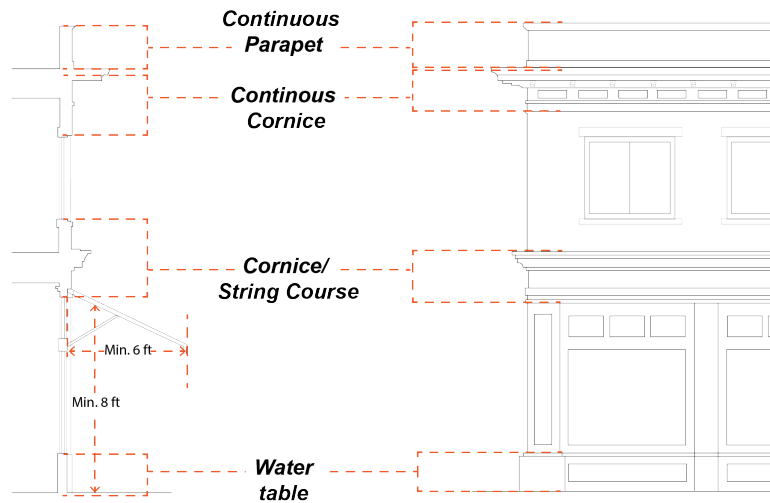
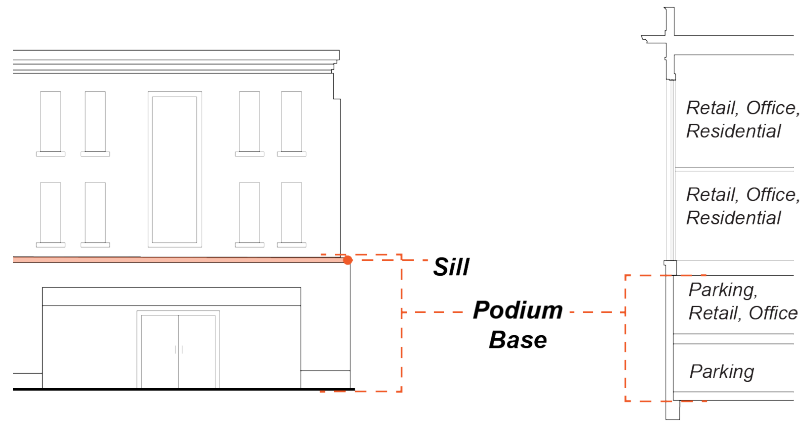

4. **Adjacencies.**

a. *Storefront Facades Adjacent to Storefront Facades.*

- i. The height of a storefront shall not differ from the height of any adjacent storefront by more than 2 feet.
- ii. The height of ground story shall not differ from height of any adjacent ground story by more than 2 feet.
- iii. Storefronts may transition in height using a module of 25 feet in length along a right-of-way.

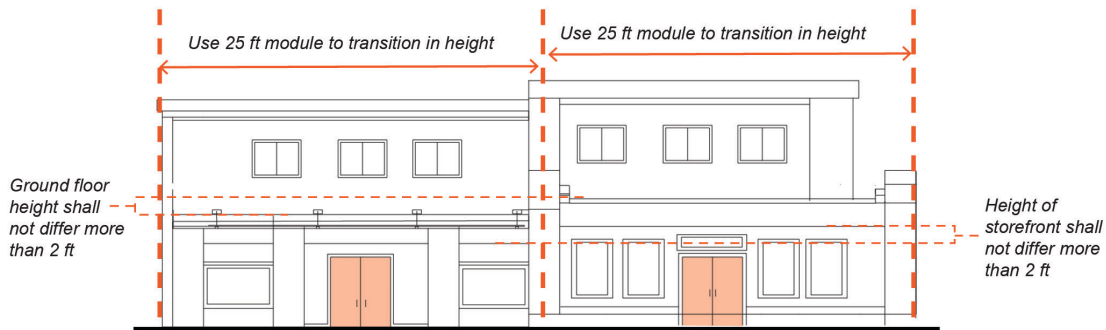

- b. **Compatibility with Adjacent Shorter Buildings with Height Difference of One Story or More.** When adjacent to an existing shorter building with a height difference of one story or more, a proposed building must utilize two or more of the following strategies:
 - i. Incorporate the uppermost floor into the roof form
 - ii. Break the mass of the building into smaller modules through changes in wall plane, setbacks, and/or height
 - iii. Match window heights and/or proportions
 - iv. Relate roof cornices and moldings at floor lines

5. **Privacy and Line of Sight.**

- a. Primary living spaces and balconies located along a side setback shall orient principal windows and balconies toward the front and rear of the building.
- b. Where windows are within 10 feet of and oriented toward an interior side setback, glazing shall either be a minimum 30-degree angle measured perpendicular to the adjacent side setback line, have minimum sill height of 42 inches, or be opaque.
- c. The maximum sill height for an ingress/egress window is 44 inches from finished floor.

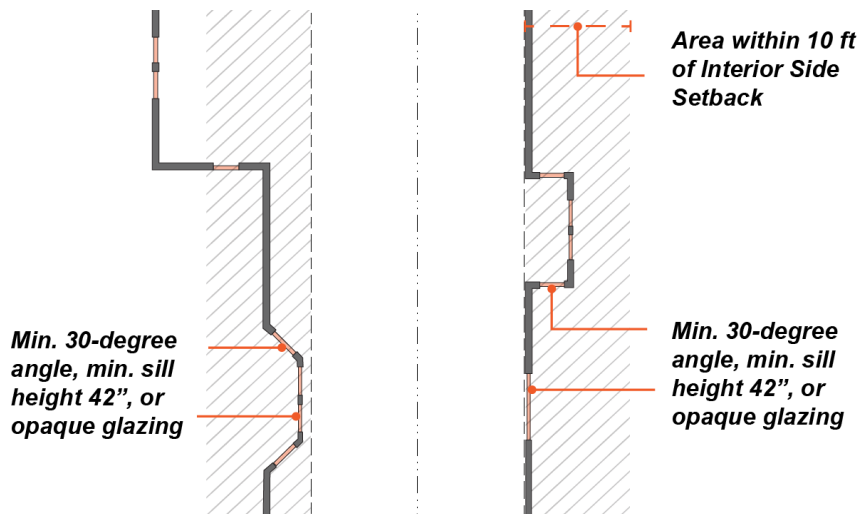

6. **Roofline and Roof Design.**

a. Roof designs shall be limited to:

- i. Hipped
- ii. Gable
- iii. Mansard

(a) Applicable for buildings 3 or more stories.

iv. Dormer

v. Parapet.

(a) When used on the first or second floor, a parapet longer than 25 feet in length must include at least one but not more than two of the following design elements to break up the length of the parapet:

- (1) Steps
- (2) Curves
- (3) Angled surfaces

(b) The length of a parapet segment on the third floor and above may not exceed 25 feet.

b. When the top story is stepped back and embedded in a sloped roof form such as a mansard roof or a hipped and/or gabled roof with dormers, the floor below must (and other floors may) be stepped back to meet the slope of the top story.

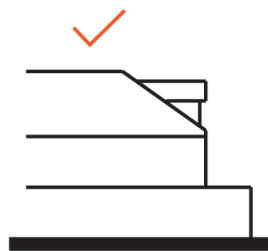

Acceptable:
One story below the story embedded in a sloped roof is also stepped-back .

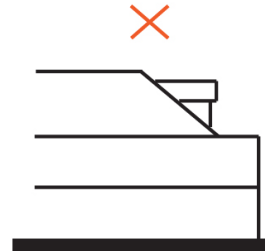

Not acceptable:
Top story embedded in a sloped roof is the only story stepped back.

c. Building façades facing an R-1 district must have a hipped or gable roof and may incorporate dormers.

- d. Roofline/parapet at corners shall not exceed roofline/parapet of adjacent wallplanes by more than 24 inches.

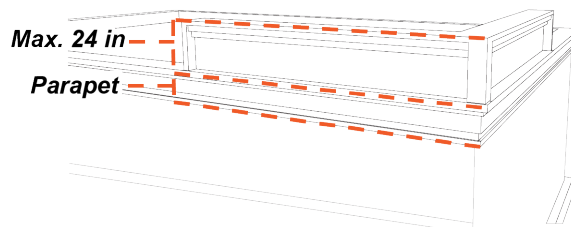

B. Building Design.

1. Façade Design.

- a. Building façade must continue the pattern established by existing buildings in Downtown Los Altos by reinforcing the underlying maximum 25-foot module along all street frontages through the use of the following techniques:
 - i. Building facades shall be arranged in an orderly composition of bays, defined by vertically aligned openings alternating horizontally with solid walls, columns, or other structural elements. The pattern shall be visually expressed through the spacing of openings, recesses, eaves, inset panels, cornices, overhangs, trellises, exposed rafters, columns, or bay windows.
 - ii. The pattern may be shared between the ground floor and upper stories provided the ground floor exhibits enhanced detail or modulation.
 - iii. Residential facades shall incorporate at least one element that signals habitation, such as bay windows, or balconies.
 - iv. Non-glazed wall areas (blank walls) at the ground level must be enhanced with architectural details, landscaping, and/or landscaped trellises or lattices.
- b. At least two of the following strategies must be used in a manner that reinforces the maximum 25-foot module:
 - i. Change in roof parapet height or shape.
 - ii. Change in roof style
 - iii. Change in materials palette
 - iv. Change in building height, minimum 8-foot difference.
 - v. Change in frontage type or change in details of Shopfront frontage type if used.
 - vi. Use of upper floor projections such as bay windows or balconies.

2. **Ground Level Transparency.** A minimum 60 percent of commercial ground floor street-facing facades between 2 and 7 feet in height shall be transparent window surface. Opaque, reflective, or dark tinted glass is not allowed.

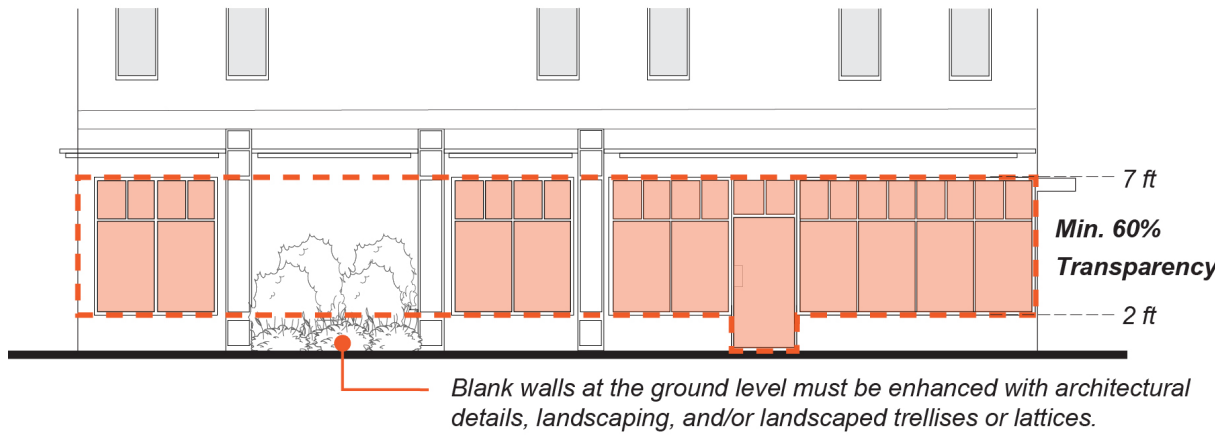

3. **Pedestrian-Scaled Entrances.**
 - a. Building entrances must incorporate at least one of the following entry features. See Section 14.66.275 (Entrance Type Standards) for design standards applicable to each entrance type listed.
 - i. Shopfront
 - (a) Shopfronts more than 25 feet in width must incorporate variations in bulkhead, awnings, materials and/or color to visually articulate the shopfront into modules not to exceed 25 continuous feet.
 - ii. Gallery
 - iii. Arcade with Shopfront frontage.
 - b. *Primary Entrance Location(s).* Locate primary entrance on the front right-of-way.
 - c. *Corner Entrances.* Chamfered corners must incorporate a building entrance. Any required entrances may be provided on the corner of the building assuming one of the intersecting sides is a primary frontage.
 - d. *Street-facing Entries to Upper Floors.* Street-facing entries to upper floors shall be equal in quality and detail to storefronts. This standard may be satisfied through two or more of the following:
 - i. Dedicated awning, canopy, or other roof element
 - ii. Stairs with a single color applied to treads and a contrasting color or pattern applied to risers.
 - iii. Dedicated light fixture(s)
 - iv. Decorative street address numbers or tiles

- v. Plaque signs for upper-floor business tenants
- e. *Entry Protection.* Primary street-facing entrances shall be protected by a recess in the building frontage at least 3 feet deep or by a projection extending outward at least 3 feet measured horizontally from the entrance, and wide enough to clear the building entryway on both sides.
- i. Protection may take the form of an extended eave, overhang, awning, door canopy, gallery, arcade frontage, or other element that provides shade and shelter from the elements.

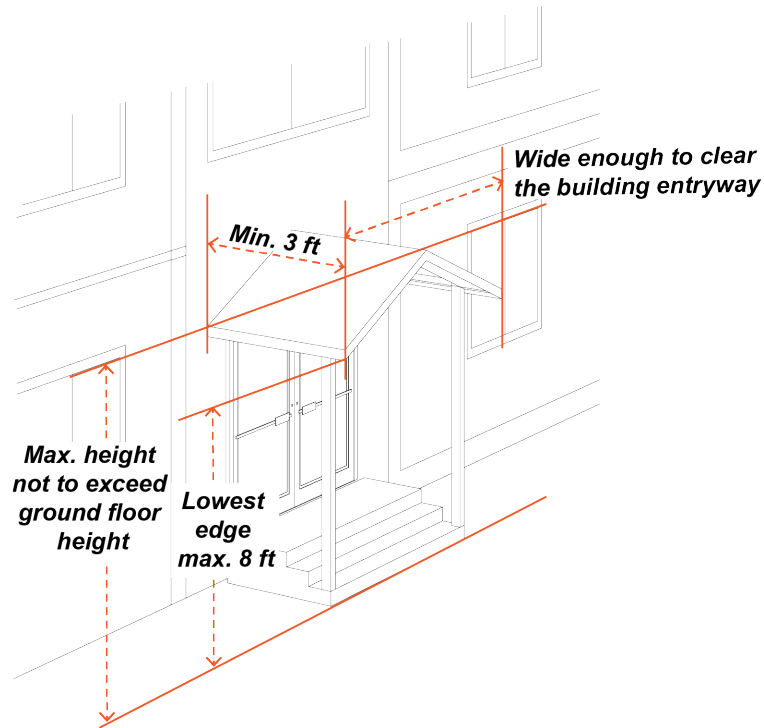

- f. Accent elements demarcating building frontage, entrance, and common open space areas shall not exceed the height of the ground floor story. Roof elements are excepted.
4. **Ground Floor Floor-to-Ceiling Height.** Minimum 24 inches taller than typical upper floor floor-to-ceiling height.

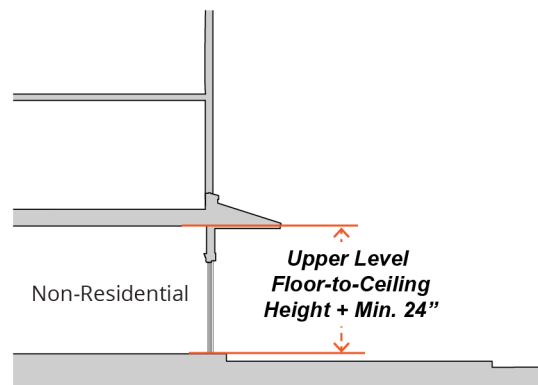

5. **Interior Courtyard.** Interior courtyards must be:
 - a. Partially visible from the street and linked to the street by a clear accessible path of travel.
 - b. Enclosed on at least two sides by buildings
 - c. Open to the sky (arbors and trellises are allowed)
 - d. A minimum width of 20 feet and a minimum area of 400 square feet.
6. **Paseos.** Paseos must be:
 - a. A minimum width of 10 feet for through-block paseos.
 - b. A minimum width of 4 feet for entries to courtyards or individual single businesses.

C. Window Design.

1. Window frames, backbands, and sills.
 - a. All windows shall have a sill.
 - i. The sill shall extend horizontally beyond the window opening or frame/casing (if present) at each end.
 - ii. The sill shall be sloped toward the outside.
 - iii. The sill shall have a drip at its outer edge.
2. Vinyl are prohibited on facades visible from a right-of-way.
3. Tinted glass is not allowed.

D. Building Materials.

1. Primary shall mean 50 percent or more of a façade surface area excluding transparent surfaces. The following primary cladding materials are allowed:
 - a. Stucco (minimum 2-coat stucco; synthetic stucco or EIFS not allowed)
 - b. Siding (lap, vertical, or shingle)
 - i. All siding shall be wood, composite wood, or cement fiberboard
 - ii. Wood siding shall be painted or stained.
 - iii. Vinyl and aluminum are not permitted.
 - c. Stone
 - d. Brick
2. Secondary shall mean less than 50 percent of a façade surface area excluding transparent surfaces. The following secondary cladding materials are allowed:
 - a. Stucco (minimum 2-coat stucco; synthetic stucco not allowed, EIFS not allowed)
 - b. Siding (lap, vertical, or shingle)

- i. All siding wood, composite wood, or cement fiberboard.
- ii. Wood siding shall be painted or stained.
- iii. Vinyl and aluminum siding are not permitted.
- c. Stone (watertable and building base only)
- d. Brick (watertable and building base only)
- e. Tile (for bulkheads below display windows and decorative accents only)
- f. Metal (matte finish or Cor-ten)
 - i. Ribbed metal, titanium, and mirrored finishes not allowed.
- g. Concrete Masonry Units (watertable and building base only, and not allowed on any façade facing a right-of-way or a single-family zone).
- h. Concrete (watertable and building base only, board-form only, cast concrete not permitted).

E. Downtown Gateway. A downtown gateway is located at the intersection of Edith Avenue, State Street, and San Antonio Road.

- 1. Building design at gateway intersection shall include:
 - a. Façade lighting; and
 - b. Overhangs or sloped roof forms.
- 2. Ground-floor design at gateway intersections must address both street frontages through:
 - a. Entrances that are visible and directly accessible from both streets;
 - b. Building transparency beyond the required minimum for the first 15 feet of building frontage from the corner;
 - c. Landscaped area with a minimum dimension of six feet; and
 - d. A usable public space with pedestrian-scaled features.

F. Landscaping and Paving, and Pedestrian Amenities

- 1. Landscaping must be placed on each side of a driveway at grade or in raised planters.
- 2. All paving located adjacent to a sidewalk must be textured (decorative or permeable).
- 3. A minimum 75 percent of on-site paving material must be pervious/permeable.
- 4. Landscape elements shall be integrated with the building architecture, parking, and streetscape. Recommended patterns shall include, but are not limited to:
 - a. Planters for flowers and shrubs within street frontage.
 - b. Landscape buffers between parking spaces and building facades.
 - c. Landscaping within and/or on walls adjacent to courtyards, open spaces, and setbacks.

- d. A publicly visible and accessible pedestrian amenity such as benches, a fountain, a rain garden, decorative paving, and/or public art.
- 5. See Sections 14.66.180 (Maintenance of Landscaped Areas) and 14.70.070 (Landscaped Strips) for additional landscaping standards.

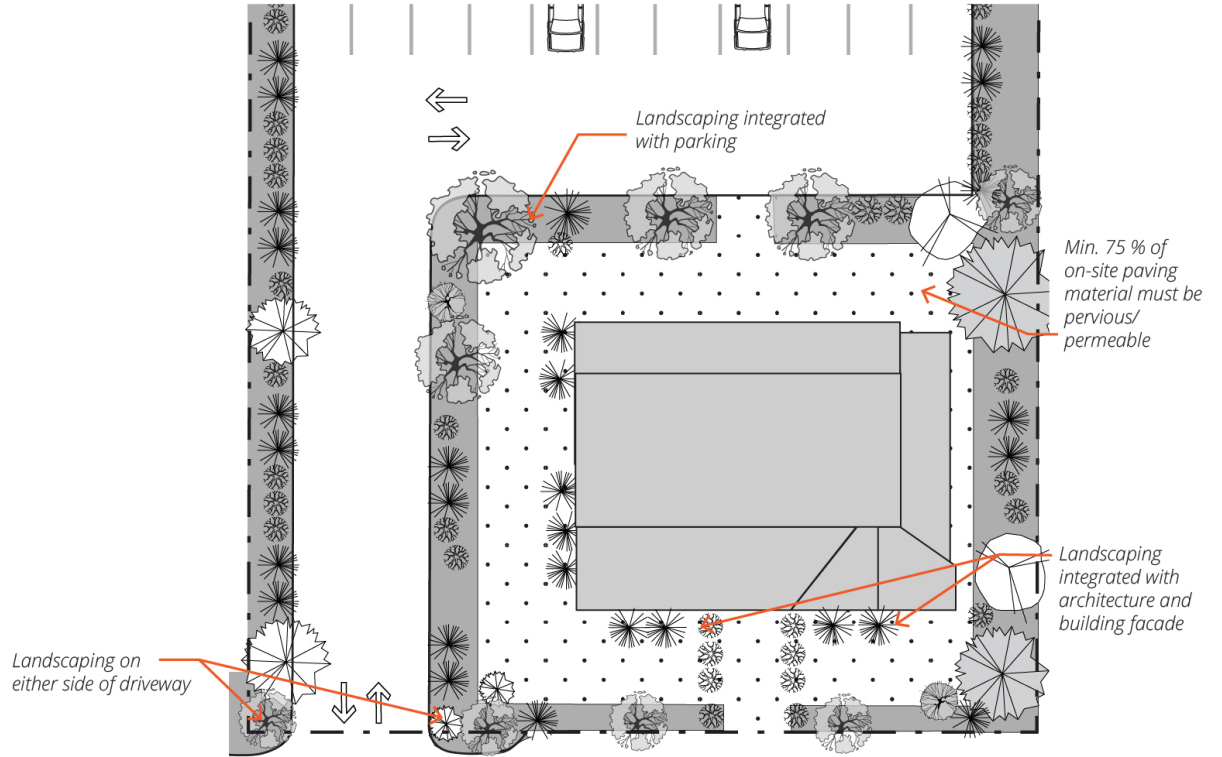

G. Parking Design and Access

- 1. Where structured parking is provided, the parking area must be either:
 - a. "Lined" with ground floor non-residential uses at least 30 feet deep as measured from the front façade; or

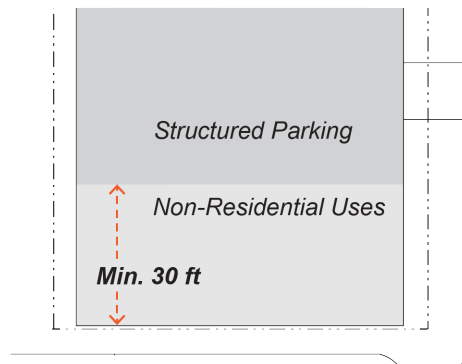

- b. Designed such that the floor elevation is a minimum 4 vertical feet below the elevation of the adjacent sidewalk.

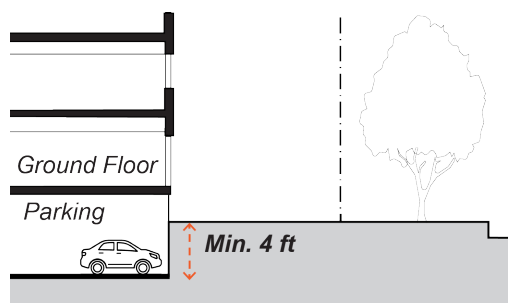

- 2. Visible structured parking must be screened from view from the right-of-way by at least one of the following features:
 - a. Regular punched openings designed to resemble windows of habitable spaces
 - b. Trellis/living wall
 - c. Custom textured or decorative screening
- 3. **Entrances to Parking Facilities.**
 - a. Controlled entrances to parking facilities (gates, doors, etc.) shall be located a minimum 10 feet from the back of sidewalk.
 - b. Entrances to parking facilities along a street frontage shall be separated by a minimum of 40 feet, excluding access to parking plazas.
 - c. Where possible, curb cuts serving adjacent parking facilities shall be shared.

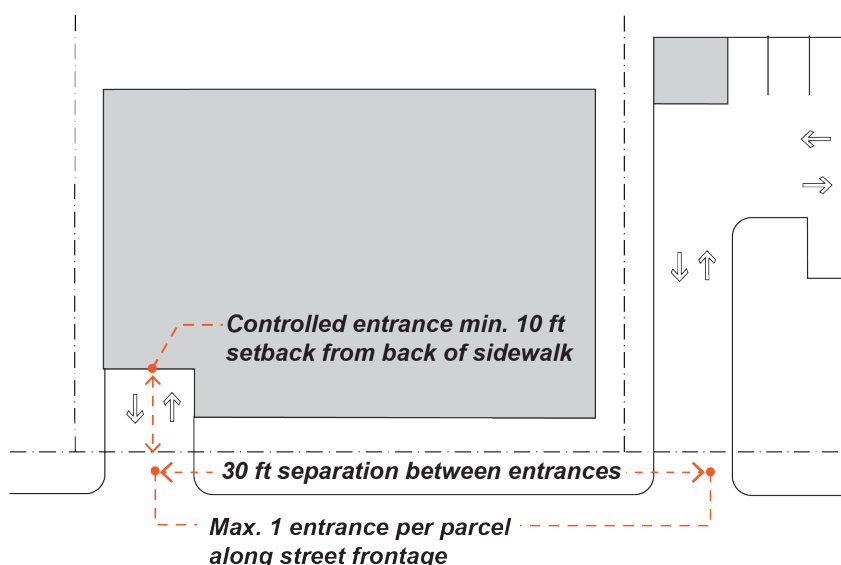

H. Site Circulation and Access

- 1. A clearly defined, lighted and landscaped pedestrian route shall be provided between all parking areas and primary pedestrian entrance.

2. New development on abutting lots shall be designed to allow cross-access for internal pedestrian, bicycle, and vehicular circulation systems.
3. Bicycle racks shall be provided:
 - a. In or within 50 feet of every parking area; and
 - b. Within 20 feet of at least one building entrance.

I. Service Areas and Screening.

1. Service areas must be located at the rear of lot or along a parking plaza.
2. Service areas must be enclosed in enclosures that are architecturally consistent with primary building in terms of materials, colors, and style.

J. Additional Design Standards. See Section 14.66.280 for additional design standards applicable to all residential mixed-use development in the CRS/OAD District.

Revised 14.16.100 Design Control (R3-4.5)

A. Building Massing and Articulation.

1. For buildings exceeding the height limit established in the applicable base and overlay zone, the right-of-way-facing facades of the uppermost floor must be embedded in a sloped roof form as allowed by Section 14.16.1100.A.4.
2. **Vertical Articulation.**
 - a. Each building volume shall be defined according to one of the following classifications:
 - i. Main Body (one per building): The widest volume of the structure, containing main entrances and the most public interior spaces.
 - ii. Wing (optional, multiple per main body allowed): A narrower volume attached to a Main Body volume.
 - b. Each Main Body volume shall contain at least one entrance.
 - c. Street-facing Wings shall be recessed by no less than 3 feet relative to the front façade of the Main Body.
 - d. The eave/roof of a Wing shall be no higher than the corresponding elements of the Main Body.
3. **R-1 Adjacencies.**
 - a. Building façade planes abutting an R-1 district may not exceed 48 feet in width.
 - b. When a building façade abutting an R-1 district exceeds 48 feet in width, it must be separated into façade bays no greater than 48 feet by a recess 5 feet wide and 5 feet deep.
 - c. Balconies, roof decks and other habitable outdoor space is not allowed on upper-story facades abutting R-1 zones.
 - d. Sliding glass doors, French doors, and floor-to-ceiling windows are not allowed on upper-story facades abutting R-1 zones.

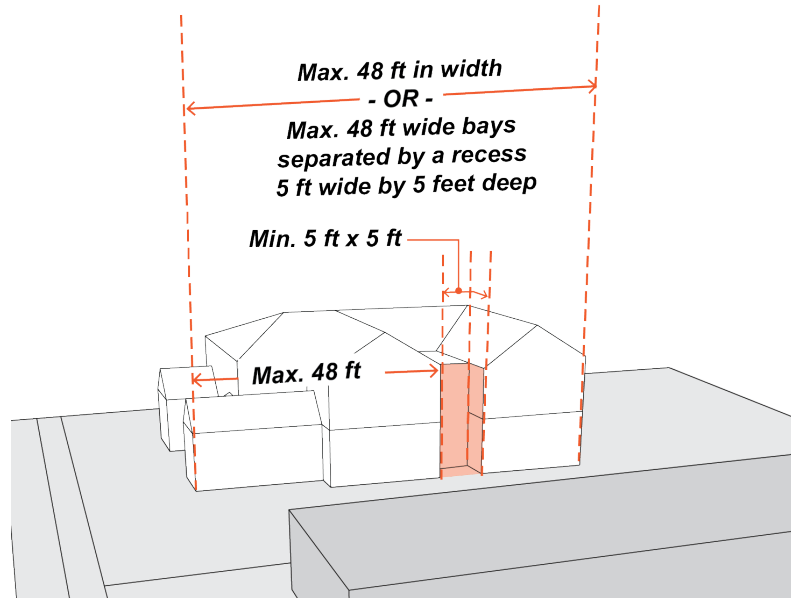

4. **Roofline and Roof Design.**

- a. Acceptable roof forms are limited to:
 - i. Hipped
 - ii. Gable
 - iii. Dormer
- b. When the top story is stepped back and embedded in a sloped roof form, the floor below must (and other floors may) be stepped back to meet the slope of the top floor.

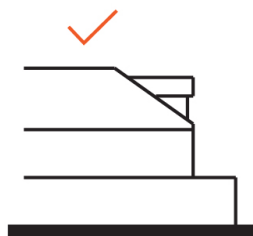

Acceptable:
 One story below the story embedded in a sloped roof is also stepped-back .

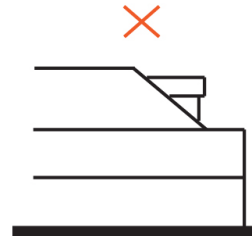

Not acceptable:
 Top story embedded in a sloped roof is the only story stepped back.

- c. Façade facing R-1 Zone must utilize a hipped or gable roof and may incorporate dormers.
- d. Roofline at corners shall not exceed roofline of adjacent wallplanes by more than 24 inches.

B. Building Design.

1. **Façade Composition.** Building facades shall be arranged in an orderly composition of bays, defined by vertically aligned openings alternating horizontally with solid walls or columns. The pattern shall be visually expressed through the spacing of openings, recesses, eaves, cornices, overhangs, trellises, exposed rafters, columns, or bay windows.
2. **Building Entrances.** Building entrances must incorporate one of the following entry features. See Section 14.66.275 (Entrance Type Standards) for design standards applicable to each entrance type listed.
 - a. Stoop
 - b. Porch
 - c. Dooryard
3. **Primary Entrance Location(s).** Locate primary entrance along the front right-of-way and/or interior courtyard.
4. **Ground Floor Floor-to-Ceiling Height.** Minimum 12 inches taller than typical upper floor floor-to-ceiling height.

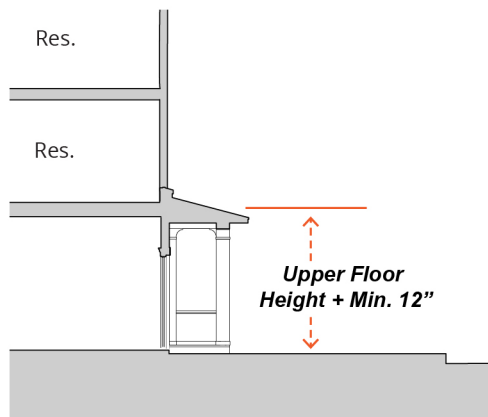

C. Window Design.

1. All windows must have a sill.
2. Vinyl sliding windows are prohibited on facades visible from a right-of-way.

D. Building Materials.

1. Primary shall mean 50 percent or more of a façade surface area excluding transparent surfaces. The following primary cladding materials are allowed:
 - a. Stucco (minimum 2-coat stucco; synthetic stucco or EIFS not allowed)
 - b. Siding (lap, vertical, or shingle)
 - i. All siding shall be wood, composite wood, or cement fiberboard.
 - ii. Wood siding shall be painted or stained.
 - iii. Vinyl and aluminum are not permitted.

- c. Stone
- d. Brick
- 2. Secondary shall mean less than 50 percent of a façade surface area excluding transparent surfaces. The following secondary cladding materials are allowed:
 - a. Stucco (minimum 2-coat stucco; synthetic stucco not allowed, EIFS not allowed)
 - b. Siding (lap, vertical, or shingle)
 - i. All siding shall be wood, composite wood, or cement fiberboard.
 - ii. Wood siding shall be painted or stained.
 - iii. Vinyl and aluminum siding are not permitted.
 - c. Stone (watertable and building base only)
 - d. Brick (watertable and building base only)
 - e. Tile
 - f. Concrete (watertable and building base only, board-form only, cast concrete not permitted).

E. Screening.

- 1. Service, trash, and utility areas must be screened from view of the right-of-way.
- 2. Screening must be architecturally consistent with primary building in terms of materials, colors, and style.

F. Topography and Grading.

- 1. A stepped foundation is required where the average slope beneath the proposed structure exceeds 10 percent.
- 2. Terracing and plantings must reflect the shape of the natural terrain.

G. Additional Design Standards. See Section 14.66.280 for additional design standards applicable to all multi-family development in the R3-4.5 District.**Revised 14.18.120 Design Control (R3-5)**

A. Building Massing and Articulation.

- 1. For buildings exceeding the height limit established in the applicable base and overlay zone, the right-of-way-facing facades of the uppermost floor must be embedded in a sloped roof form as allowed by Section 14.18.120.A.4.
- 2. **Vertical Articulation**
 - a. Each building volume shall be defined according to one of the following classifications:

- i. Main Body (one per building): The widest volumes of the structure, containing main entrances and the most public interior spaces.
 - ii. Wing (optional, multiple per main body allowed): A narrower volume attached to a Main Body volume.
- b. Each Main Body volume shall contain at least one entrance.
 - c. Street-facing Wings shall be recessed by no less than 3 feet relative to the front façade of the Main Body.
 - d. The eave/roof of a Wing shall be no higher than the corresponding elements of the Main Body.

3. **R-1 Adjacencies.**

- a. Building façade planes abutting an R-1 district may not exceed 48 feet in width.
- b. When a building façade abutting an R-1 district exceeds 48 feet in width, it must be separated into façade bays no greater than 48 feet by a recess 5 feet wide and 5 feet deep.
- c. Balconies, roof decks and other habitable outdoor space is not allowed on upper-story facades abutting R-1 zones.
- d. Sliding glass doors, French doors, and floor-to-ceiling windows are not allowed on upper-story facades abutting R-1 zones.

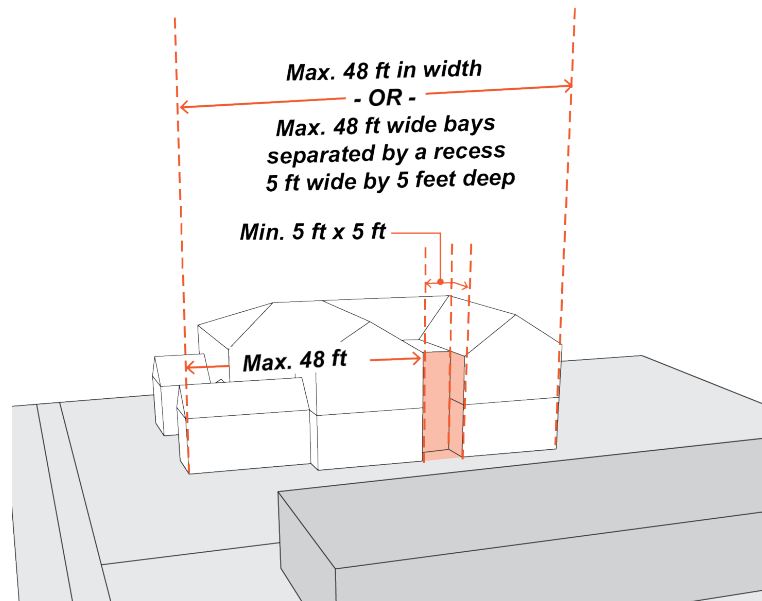

4. **Roofline and Roof Design.**

- a. Acceptable roof forms:
 - i. Hipped
 - ii. Gable
 - iii. Dormer

- b. When the top story is stepped back and embedded in a sloped roof form such as a mansard roof or a hipped and/or gabled roof with dormers, the floor below must (and other floors may) be stepped back to meet the slope of the top story.

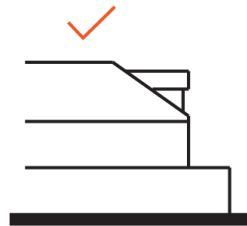

Acceptable:
One story below the story embedded in a sloped roof is also stepped-back .

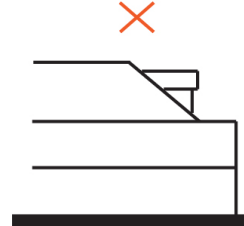

Not acceptable:
Top story embedded in a sloped roof is the only story stepped back.

- c. Façade facing R-1 Zone must utilize a hipped or gable roof and may incorporate dormers.
- d. Roofline at corners shall not exceed roofline of adjacent wallplanes by more than 24 inches.

B. Building Design.

1. **Façade Composition.** Building facades shall be arranged in an orderly composition of bays, defined by vertically aligned openings alternating horizontally with solid walls or columns. The pattern shall be visually expressed through the spacing of openings, recesses, eaves, cornices, overhangs, trellises, exposed rafters, columns, or bay windows.
2. **Building Entrances.** Building entrances must incorporate one of the following entry features. See Section 14.66.275 (Entrance Type Standards) for design standards applicable to each entrance type listed.
 - a. Stoop
 - b. Porch
 - c. Dooryard
3. **Primary Entrance Location(s).** Locate primary entrance on the front ROW and/or interior courtyard.
4. **Ground Floor Floor-to-Ceiling Height.** Minimum 12 inches taller than typical upper floor floor-to-ceiling height.

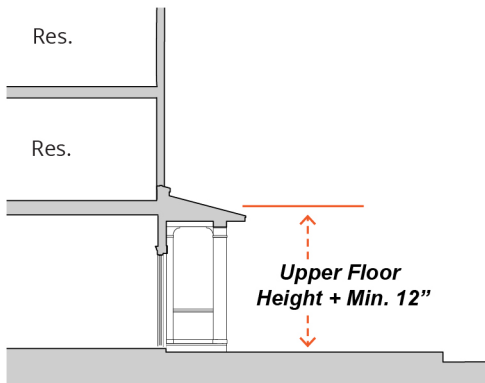

C. Window Design.

1. All windows must have a sill.
2. Vinyl sliding windows are prohibited on facades visible from a right-of-way.

D. Building Materials.

1. Primary shall mean 50 percent or more of a façade surface area excluding transparent surfaces. The following primary cladding materials are allowed:
 - a. Stucco (minimum 2-coat stucco; synthetic stucco or EIFS not allowed)
 - b. Siding (lap, vertical, or shingle)
 - i. All siding shall be wood, composite wood, or cement fiberboard.
 - ii. Wood siding shall be painted or stained.
 - iii. Vinyl and aluminum siding are not permitted.
 - c. Stone
 - d. Brick
2. Secondary shall mean less than 50 percent of a façade surface area excluding transparent surfaces. The following secondary cladding materials are allowed:
 - a. Stucco (minimum 2-coat stucco; synthetic stucco not allowed, EIFS not allowed)
 - b. Siding (lap, vertical, or shingle)
 - i. All siding shall be wood, composite wood, or cement fiberboard.
 - ii. Wood siding shall be painted or stained.
 - iii. Vinyl and aluminum siding are not permitted.
 - c. Stone (watertable and building base only)
 - d. Brick (watertable and building base only)
 - e. Tile
 - f. Concrete (watertable and building base only, board-form only, cast concrete not permitted).

E. Landscaping.

1. Landscaping must be placed on each side of a driveway at grade or in raised planters.
2. Low walls and/or hedges must screen the parking along the sidewalk. When walls are used, the materials and design must be compatible with and not obscure the architectural style of the building.

F. Screening.

1. Service, trash, and utility areas must be screened from view of the right-of-way.
2. Screening must be architecturally consistent with primary building in terms of materials, colors, and style.

G. Additional Design Standards. See Section 14.66.280 for additional design standards applicable to all multi-family development in the R3-5 District.

Revised 14.20.120 Design Control (R3-3)

A. Building Massing and Articulation.

1. For buildings exceeding the height limit established in the applicable base and overlay zone, the right-of-way-facing facades of the uppermost floor must be embedded in a sloped roof form as allowed by Section 14.20.120.A.4.
2. **Vertical Articulation**
 - a. Each building volume shall be defined according to one of the following classifications:
 - i. Main Body (one per building): The widest volumes of the structure, containing main entrances and the most public interior spaces.
 - ii. Wing (optional, multiple per main body allowed): A narrower volume attached to a Main Body volume.
 - b. Each Main Body volume shall contain at least one entrance.
 - c. Street-facing Wings shall be recessed by no less than 3 feet relative to the front façade of the Main Body.
 - d. The eave/roof of a Wing shall be no higher than the corresponding elements of the Main Body.
3. **R-1 Adjacencies.**
 - a. Building façade planes abutting an R-1 district may not exceed 48 feet in width.
 - b. When a building façade abutting an R-1 district exceeds 48 feet in width, it must be separated into façade bays no greater than 48 feet by a recess 5 feet wide and 5 feet deep.
 - c. Balconies, roof decks and other habitable outdoor space is not allowed on upper-story facades abutting R-1 zones.
 - d. Sliding glass doors, French doors, and floor-to-ceiling windows are not allowed on upper-story facades abutting R-1 zones.

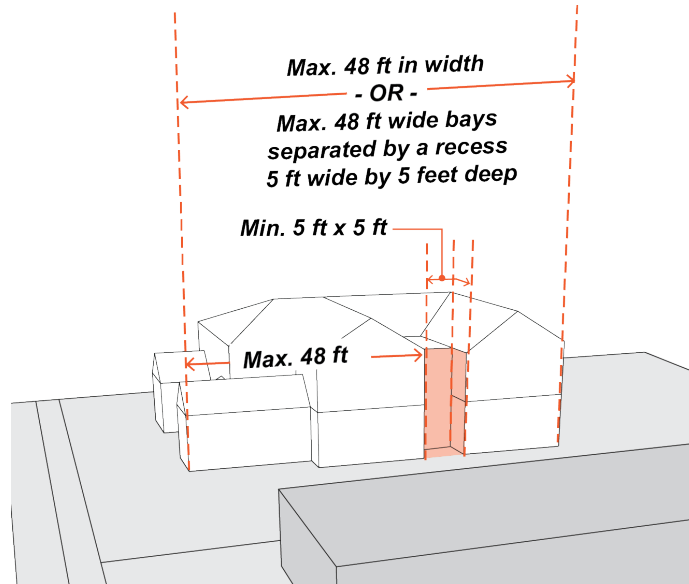

4. **Roofline and Roof Design.**

a. Acceptable roof forms:

- i. Hipped
- ii. Gable
- iii. Dormer

b. When the top story is stepped back and embedded in a sloped roof form such as a mansard roof or a hipped and/or gabled roof with dormers, the floor below must (and other floors may) be stepped back to meet the slope of the top story.

c. Façade facing R-1 Zone must utilize a hipped or gable roof and may

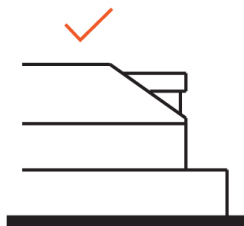

Acceptable:
One story below the story embedded in a sloped roof is also stepped-back .

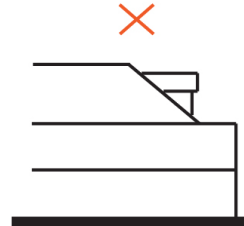

Not acceptable:
Top story embedded in a sloped roof is the only story stepped back.

incorporate dormers.

d. Roofline at corners shall not exceed roofline of adjacent wallplanes by more than 24 inches.

B. Building Design.

1. **Façade Composition.** Building facades shall be arranged in an orderly composition of bays, defined by vertically aligned openings alternating horizontally with solid walls or columns. The pattern shall be visually expressed through the spacing of openings, recesses, eaves, cornices, overhangs, trellises, exposed rafters, columns, or bay windows.
2. **Building Entrances.** Building entrances must incorporate one of the following entry features. See Section 14.66.275 (Entrance Type Standards) for design standards applicable to each entrance type listed.
 - a. Stoop
 - b. Porch
 - c. Dooryard
3. **Primary Entrance Location(s).** Locate primary entrance along the front right-of-way and/or interior courtyard.
4. **Ground Floor Floor-to-Ceiling Height.** Minimum 12 inches taller than typical upper floor floor-to-ceiling height.

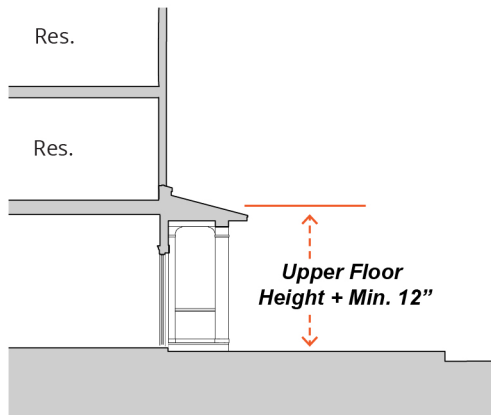

C. Window Design.

1. All windows must have a sill.
2. Vinyl sliding windows are prohibited on facades visible from a right-of-way.

D. Building Materials.

1. Primary shall mean 50 percent or more of a façade surface area excluding transparent surfaces. The following primary cladding materials are allowed:
 - a. Stucco (minimum 2-coat stucco; synthetic stucco or EIFS not allowed)
 - b. Siding (lap, vertical, or shingle)
 - i. All siding shall be wood, composite wood, or cement fiberboard.
 - ii. Wood siding shall be painted or stained.
 - iii. Vinyl and aluminum siding are not permitted.

- c. Stone
 - d. Brick
2. Secondary shall mean less than 50 percent of a façade surface area excluding transparent surfaces. The following secondary cladding materials are allowed:
- a. Stucco (minimum 2-coat stucco; synthetic stucco not allowed, EIFS not allowed)
 - b. Siding (lap, vertical, or shingle)
 - i. All siding shall be wood, composite wood, or cement fiberboard.
 - ii. Wood siding shall be painted or stained.
 - iii. Vinyl and aluminum siding are not permitted.
 - c. Stone (watertable and building base only)
 - d. Brick (watertable and building base only)
 - e. Tile
 - f. Concrete (watertable and building base only, board-form only, cast concrete not permitted).

E. Landscaping.

- 1. Landscaping must be placed on each side of a driveway at grade or in raised planters.
- 2. Low walls and/or hedges must screen the parking along the sidewalk. When walls are used, the materials and design must be compatible with and not obscure the architectural style of the building.

F. Screening.

- 1. Service, trash, and utility areas must be screened from view of the right-of-way.
- 2. Screening must be architecturally consistent with primary building in terms of materials, colors, and style.

G. Additional Design Standards. See Section 14.66.280 for additional design standards applicable to all multi-family development in the R3-3 District.

Revised 14.22.110 Design Control (R3-1.8)

A. Building Massing and Articulation.

1. **Upper-story Step-backs.**

- a. *Front:* Minimum 5 feet from ground floor façade for third story and above for building facades 50 feet or greater in width.
- b. *Street Side:* Minimum 5 feet from ground floor façade for third story and above for building facades 50 feet or greater in width.
- c. For buildings exceeding the height limit established in the applicable base and overlay zone, the right-of-way-facing facades of the uppermost floor must be embedded in a sloped roof form as allowed by Section 14.22.110.A.4.

2. **Vertical Articulation**

- a. Each building volume shall be defined according to one of the following classifications:
 - i. Main Body (one per building): The widest volumes of the structure, containing main entrances and the most public interior spaces.
 - ii. Wing (optional, multiple per main body allowed): A narrower volume attached to a Main Body volume.
- b. Each Main Body volume shall contain at least one entrance.
- c. Street-facing Wings shall be recessed by no less than 3 feet relative to the front façade of the Main Body.
- d. The eave/roof of a Wing shall be no higher than the corresponding elements of the Main Body.

3. **R-1 Adjacencies.**

- a. Building façade planes abutting an R-1 district may not exceed 48 feet in width.
- b. When a building façade abutting an R-1 district exceeds 48 feet in width, it must be separated into façade bays no greater than 48 feet by a recess 5 feet wide and 5 feet deep.
- c. Balconies, roof decks and other habitable outdoor space is not allowed on upper-story facades abutting R-1 zones.
- d. Sliding glass doors, French doors, and floor-to-ceiling windows are not allowed on upper-story facades abutting R-1 zones.

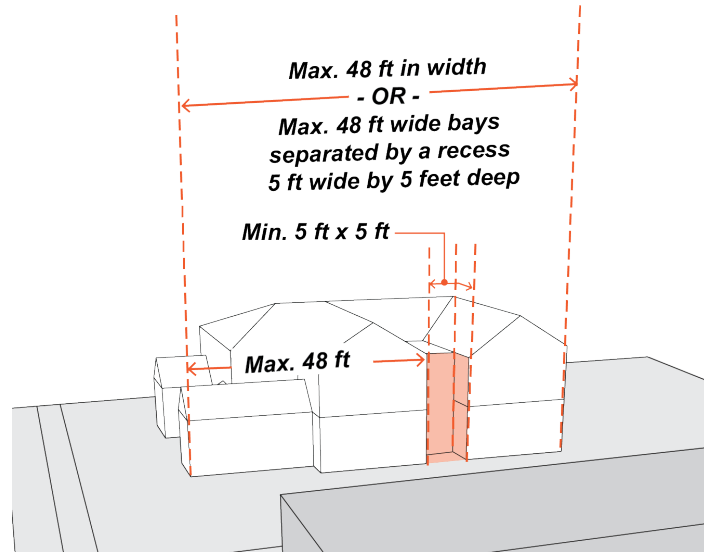

4. **Roofline and Roof Design.**

- a. Acceptable roof forms:
 - i. Hipped
 - ii. Gable
 - iii. Dormer
- b. When the top story is stepped back and embedded in a sloped roof form such as a mansard roof or a hipped and/or gabled roof with dormers, the floor below must (and other floors may) be stepped back to meet the slope of the top story.



Acceptable:
 One story below the story embedded in a sloped roof is also stepped-back .

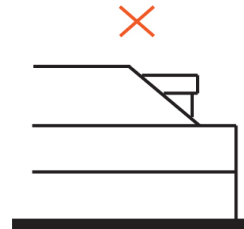

Not acceptable:
 Top story embedded in a sloped roof is the only story stepped back.

- c. Façade facing R-1 Zone must utilize a hipped or gable roof and may incorporate dormers.
- d. Roofline at corners shall not exceed roofline of adjacent wallplanes by more than 24 inches.

B. Building Design.

1. **Façade Composition.** Building facades shall be arranged in an orderly composition of bays, defined by vertically aligned openings alternating horizontally with solid walls or columns. The pattern shall be visually expressed through the spacing of openings, recesses, eaves, cornices, overhangs, trellises, exposed rafters, columns, or bay windows.
2. **Building Entrances.** Building entrances must incorporate one of the following entry features. See Section 14.66.275 (Entrance Type Standards) for design standards applicable to each entrance type listed.
 - a. Stoop
 - b. Porch
 - c. Dooryard
3. **Primary Entrance Location(s).** Locate primary entrance on the front ROW and/or interior courtyard.
4. **Ground Floor Floor-to-Ceiling Height.** Minimum 12 inches taller than typical upper floor floor-to-ceiling height.

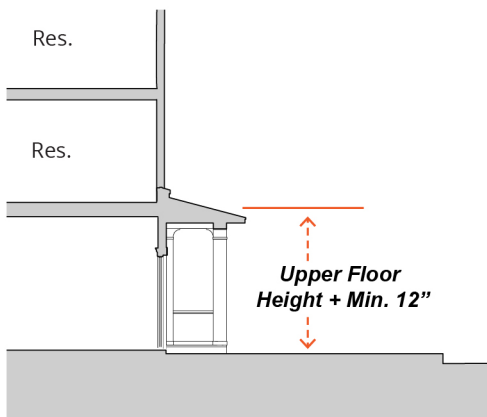

- C. Storage.** Each multi-family residential dwelling unit shall have a minimum of ninety-six (96) cubic feet of enclosed storage, excluding closet and garage areas.

D. Window Design.

1. All windows must have a sill.
2. Vinyl sliding windows are prohibited on facades visible from a Right of Way.

E. Building Materials.

1. Primary shall mean 50 percent or more of a façade surface area excluding transparent surfaces. The following primary cladding materials are allowed:
 - a. Stucco (minimum 2-coat stucco; synthetic stucco or EIFS not allowed)
 - b. Siding (lap, vertical, or shingle)
 - i. All siding shall be wood, composite wood, or cement fiberboard.

- ii. Wood siding shall be painted or stained.
 - iii. Vinyl and aluminum siding are not permitted.
 - c. Stone
 - d. Brick
- 2. Secondary shall mean less than 50 percent of a façade surface area excluding transparent surfaces. The following secondary cladding materials are allowed:
 - a. Stucco (minimum 2-coat stucco; synthetic stucco not allowed, EIFS not allowed)
 - b. Siding (lap, vertical, or shingle)
 - i. All siding shall be wood, composite wood, or cement fiberboard
 - ii. Wood siding shall be painted or stained
 - iii. Vinyl and aluminum siding are not permitted
 - c. Stone (watertable and building base only)
 - d. Brick (watertable and building base only)
 - e. Tile
 - f. Concrete (watertable and building base only, board-form only, cast concrete not permitted)

F. Landscaping.

- 1. Landscaping must be placed on each side of a driveway at grade or in raised planters.
- 2. Low walls and/or hedges must screen the parking along the sidewalk. When walls are used, the materials and design must be compatible with and not obscure the architectural style of the building.

G. Screening.

- 1. Service, trash, and utility areas must be screened from view of the right-of-way.
- 2. Screening must be architecturally consistent with primary building in terms of materials, colors, and style.

H. Additional Design Standards. See Section 14.66.280 for additional design standards applicable to all multi-family development in the R3-1.8 District.

Revised 14.24.110 Design Control (R3-1)

A. Building Placement. A minimum 85 percent of the building frontage must be built at the minimum setback line. This standard applies to the building frontage only (exclusive of side setbacks).

B. Building Massing and Articulation.

1. **Upper-story Step-backs.**

- a. *Front:* Minimum 5 feet from ground floor façade for fourth story and above for building facades 50 feet or greater in width.
- b. *Street Side:* Minimum 5 feet from ground floor façade for fourth story and above for building facades 50 feet or greater in width.
- c. *Interior Side and Rear Abutting an R-1 District:* Minimum 5 feet from ground floor façade for fourth story and above.
- d. For buildings exceeding the height limit established in the applicable base and overlay zone, the right-of-way-facing facades of the uppermost floor must be embedded in a sloped roof form as allowed by Section 14.24.110.A.5.

2. **Vertical Articulation.** When a building façade exceeds 50 feet in length along a right of way, it must be separated into primary façade bays no greater than 50 feet and secondary façade bays defined by a recess a minimum of 3 feet deep.



3. **R-1 Adjacencies.**

- a. Building façade planes abutting an R-1 district may not exceed 48 feet in width.
- b. When a building façade abutting an R-1 district exceeds 48 feet in width, it must be separated into façade bays no greater than 48 feet by a recess 5 feet wide and 5 feet deep.

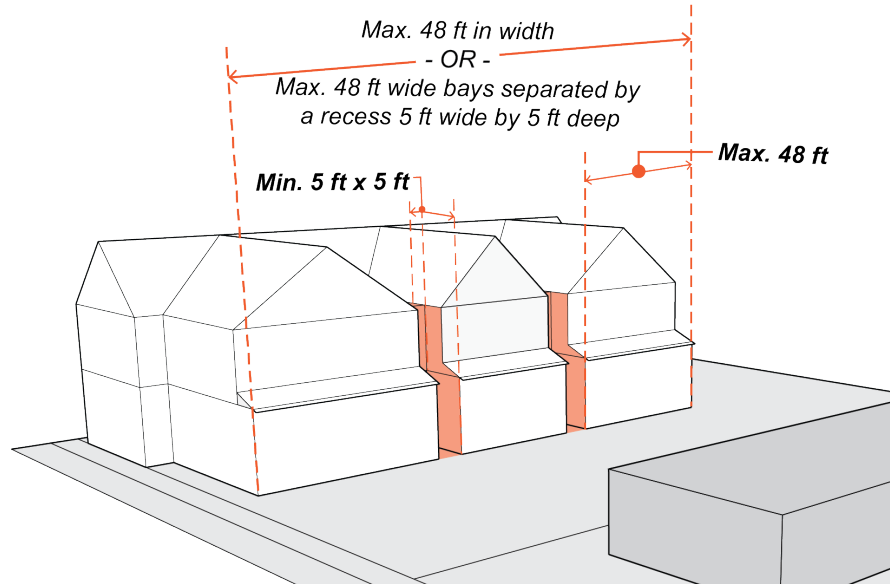

- c. Balconies, roof decks and other habitable outdoor space is not allowed on upper-story facades abutting R-1 zones.
- d. Sliding glass doors, French doors, and floor-to-ceiling windows are not allowed on upper-story facades abutting R-1 zones.

4. **Privacy and Line of Sight.**

- a. Primary living spaces and balconies located along a side setback shall orient principal windows and balconies toward the front and rear of the building.
- b. Where windows are within 10 feet of and oriented toward an interior side setback, glazing shall either be a minimum 30-degree angle measured perpendicular to the adjacent side setback line, have minimum sill height of 42 inches, or be opaque.
- c. The maximum sill height for an ingress/egress window is 44 inches from finished floor.

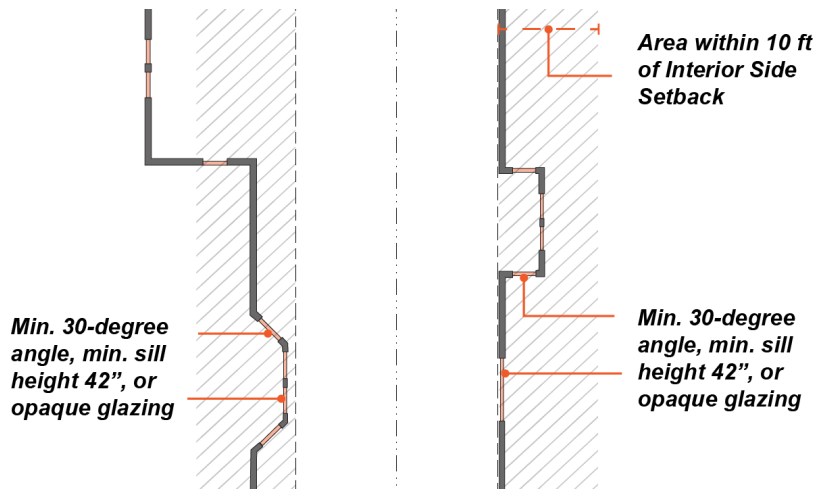

5. **Roofline and Roof Design.**

- a. Roof designs shall be limited to:
 - i. Hipped
 - ii. Gable
 - iii. Dormer
 - iv. Parapet
 - (a) When used on the first or second floor, a parapet longer than 25 feet in length must include at least one but not more than two of the following design elements to break up the length of the parapet:
 - (1) Steps
 - (2) Curves
 - (3) Angled surfaces
 - (b) Parapet limited to 25 percent of cumulative roof perimeter on the third floor and above.
 - (c) The length of a parapet segment on the third floor and above may not exceed 25 feet.
- b. When the top story is stepped back and embedded in a sloped roof form such as a mansard roof or a hipped and/or gabled roof with dormers, the floor below must (and other floors may) be stepped back to meet the slope of the top story.

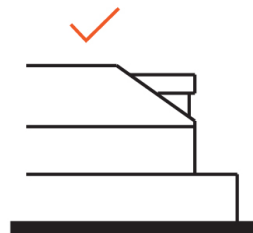

Acceptable:
One story below the story embedded in a sloped roof is also stepped-back .

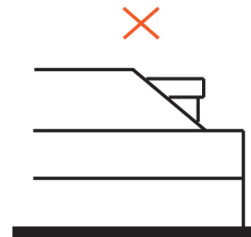

Not acceptable:
Top story embedded in a sloped roof is the only story stepped back.

- c. Façade facing R-1 Zone must utilize a hipped or gable roof and may incorporate dormers.
- d. Corner Treatment. Roofline/parapet at corners shall not exceed roofline/parapet of adjacent wallplanes by more than 24 inches.

C. Building Design.

1. ***Façade Composition.***

- a. Building facades must continue the pattern established by existing buildings in Downtown Los Altos by reinforcing the underlying maximum 25-foot module along all street frontages through the use of the following techniques:
 - i. Building facades shall be arranged in an orderly composition of bays, defined by vertically aligned openings alternating horizontally with solid walls or columns.
 - ii. The pattern shall be visually expressed through the spacing of openings, recesses, eaves, cornices, overhangs, trellises, exposed rafters, columns, or bay windows.
 - iii. Facades shall incorporate at least one element that signals habitation, such as porches, bay windows, or balconies.
 - iv. Non-glazed wall areas (blank walls) at the ground level must be enhanced with architectural details, landscaping, and/or landscaped trellises or lattices.
- a. At least two of the following strategies must be used in a manner that reinforces the maximum 25-foot module:
 - i. Change in roof parapet height or shape.
 - ii. Change in roof style
 - iii. Change in materials palette
 - iv. Change in building height, minimum 8-foot difference.
 - v. Change in frontage type or change in details of Shopfront frontage type if used.
 - vi. Use of upper floor projections such as bay windows or balconies.

2. ***Building Entrances.*** Building entrances must incorporate one of the following entry features. See Section 14.66.275 (Entrance Type Standards) for design standards applicable to each entrance type listed.

- a. Stoop
- b. Porch
- c. Dooryard
- d. Gallery
- e. Arcade
- f. Forecourt
 - i. Forecourts must feature at least one entry to a shop and/or second floor use.

- ii. Forecourts for buildings more than 70 feet in length along a right-of-way must have a minimum width and depth of 15 feet from front façade. Width of forecourt shall be equal to or greater than depth.
 - iii. The size of the forecourt must be appropriate relative to the size of the building. The maximum ratio of building height to forecourt is 2:1 (height < 2 x width).
 - iv. Forecourt must be enclosed on at least three sides by buildings.
 - v. Forecourt must remain open to the sky (arbors and trellises are allowed).
- g. Terrace
3. **Primary Entrance Location(s).** Locate primary entrance on the front ROW and/or interior courtyard.
 4. **Individual Entries.** Ground floor residential units facing a street must provide individual entries along the street frontage.
 5. **Interior Courtyard.** Interior courtyards must be:
 - a. Enclosed on at least two sides by buildings
 - b. Open to the sky (arbors and trellises are allowed)
 - c. A minimum width of 20 feet and a minimum area of 400 square feet.
 6. **Paseos.** Paseos must be:
 - a. A minimum width of 10 feet for through-block paseos
 - b. A minimum width of 4 feet for entries to courtyards or individual single businesses.
 7. **Ground Floor Floor-to-Ceiling Height.** Minimum 12 inches taller than typical upper floor floor-to-ceiling height.

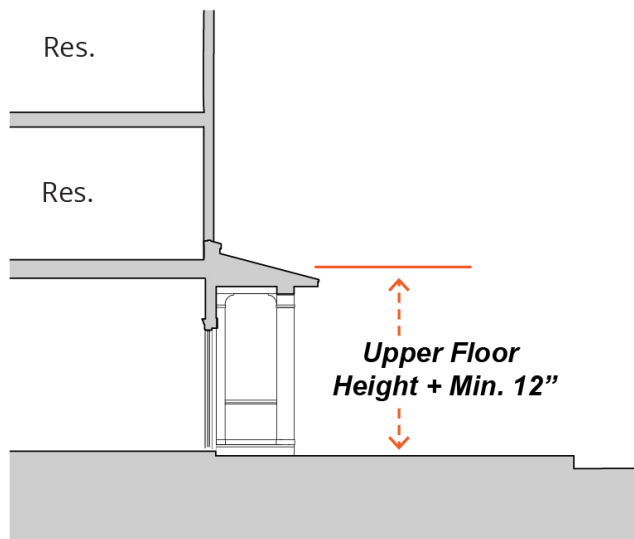

D. Window Design.

1. All windows must have a sill.
2. Vinyl sliding windows are prohibited on facades visible from a right-of-way.

E. Building Materials.

1. Primary shall mean 50 percent or more of a façade surface area excluding transparent surfaces. The following primary cladding materials are allowed:
 - a. Stucco (minimum 2-coat stucco; synthetic stucco or EIFS not allowed)
 - b. Siding (lap, vertical, or shingle)
 - i. All siding shall be wood, composite wood, or cement fiberboard.
 - ii. Wood siding shall be painted or stained.
 - iii. Vinyl and aluminum siding are not permitted.
 - c. Stone
 - d. Brick
2. Secondary shall mean less than 50 percent of a façade surface area excluding transparent surfaces. The following secondary cladding materials are allowed:
 - a. Stucco (minimum 2-coat stucco; synthetic stucco not allowed, EIFS not allowed)
 - b. Siding (lap, vertical, or shingle)
 - i. All siding shall be wood, composite wood, or cement fiberboard.
 - ii. Wood siding shall be painted or stained.
 - iii. Vinyl and aluminum siding are not permitted.
 - c. Stone (watertable and building base only)
 - d. Brick (watertable and building base only)
 - e. Tile
 - f. Metal (matte finish or Cor-ten)
 - i. Ribbed metal, titanium, and mirrored finishes not allowed
 - g. Concrete Masonry Units (watertable and building base only, and not allowed on any façade facing a right-of-way or a single-family zone).
 - h. Concrete (watertable and building base only, board-form only, cast concrete not permitted).

F. Landscaping and Paving.

1. Landscaping must be placed on each side of a driveway at grade or in raised planters.
2. Low walls and/or hedges must screen the parking along the sidewalk. When walls are used, the materials and design must be compatible with and not obscure the architectural style of the building.

Revised 14.24.110 Design Control (R3-1)

3. A minimum 75 percent of on-site paving material must be pervious/permeable.

G. Screening.

1. Service areas must be located at the rear of lot or along a parking plaza.
2. Screening must be architecturally consistent with primary building in terms of materials, colors, and style.

H. Additional Design Standards. See Section 14.66.280 for additional design standards applicable to all multi-family development in the R3-1 District.

New Section 14.66.275 Entrance Type Standards

A. Stoop

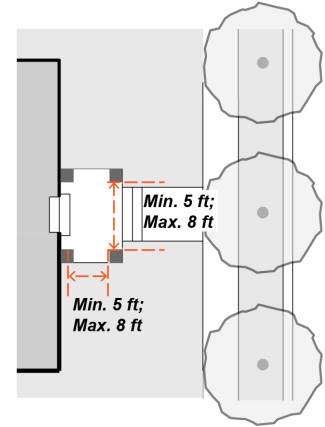
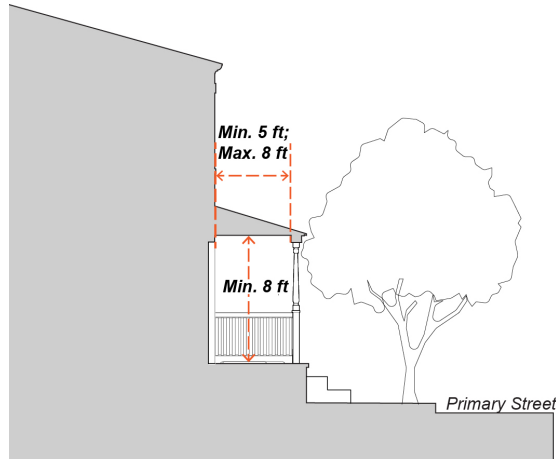

B. Porch

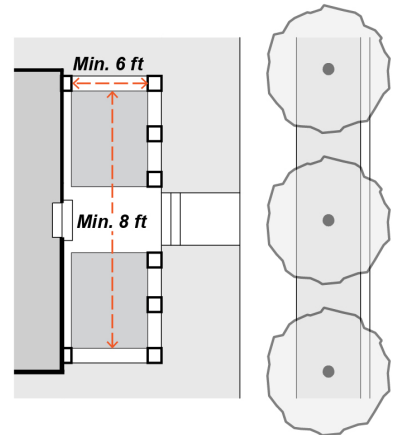
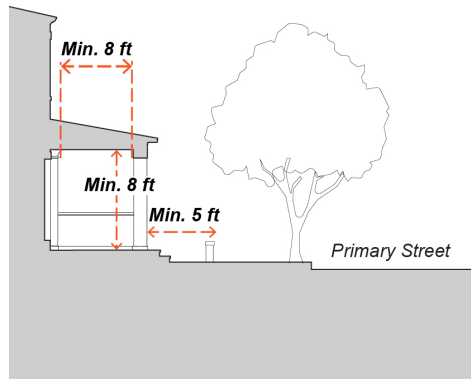

New Section 14.66.275 Entrance Type Standards

C. Dooryard

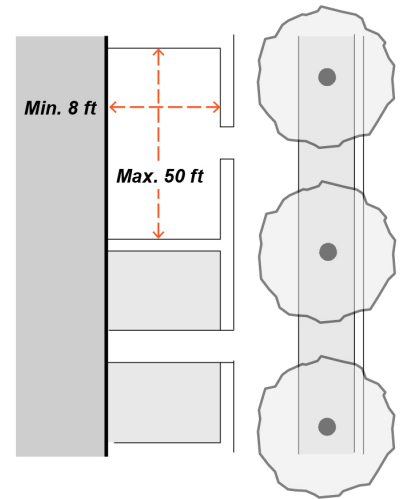
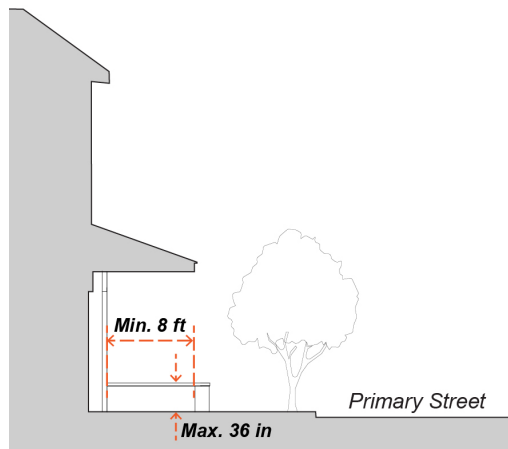

D. Shopfront

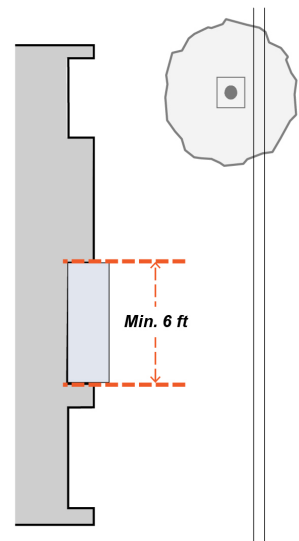
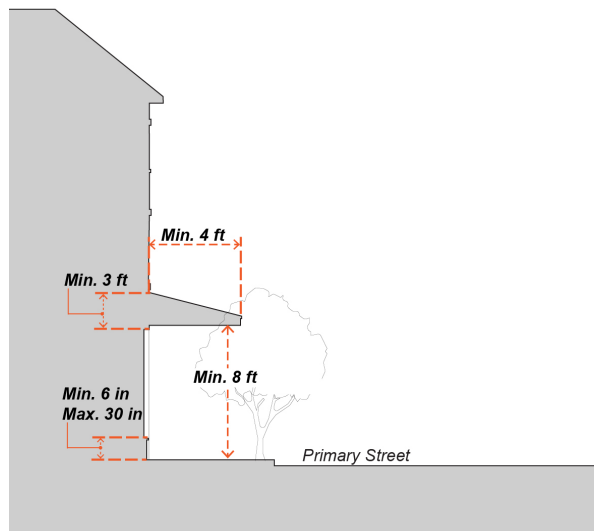

E. Gallery



F. Arcade

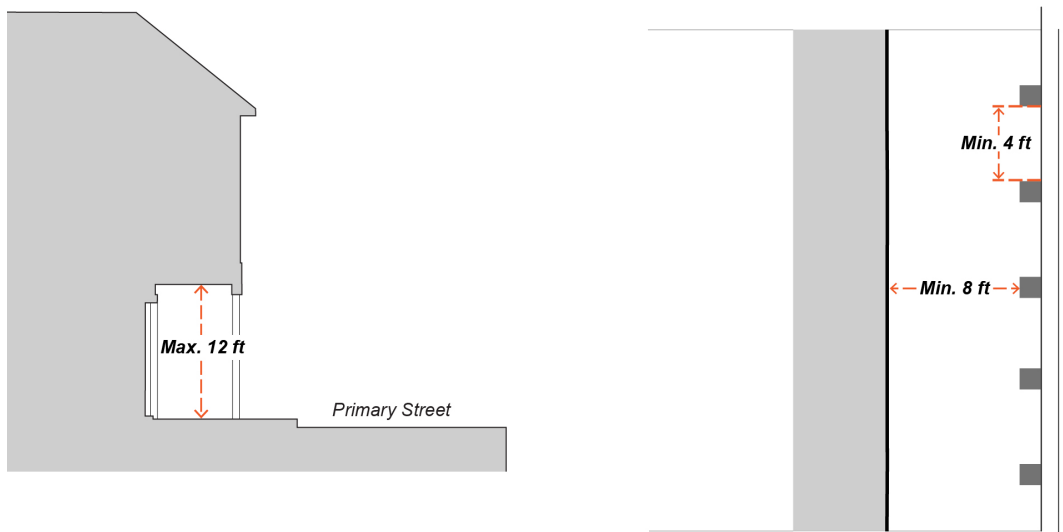

New Section 14.66.275 Entrance Type Standards

G. Forecourt

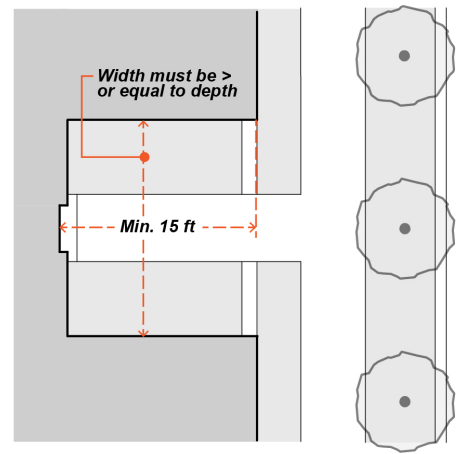
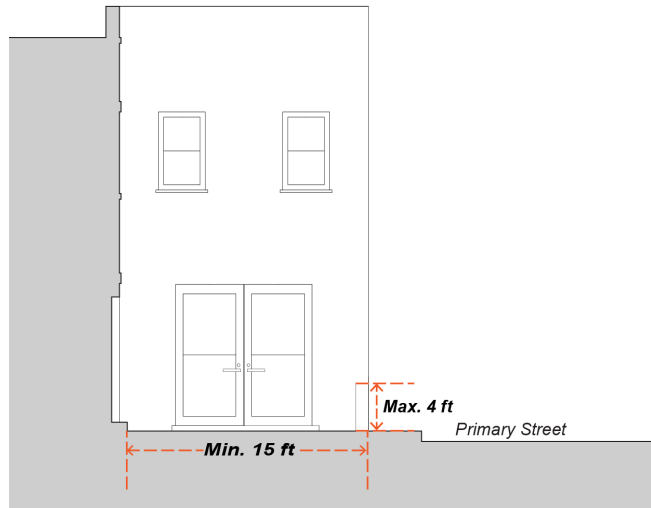

H. Terrace

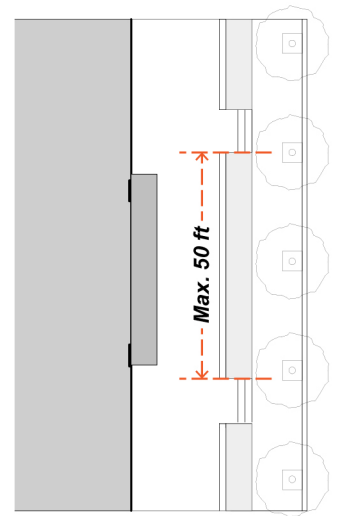
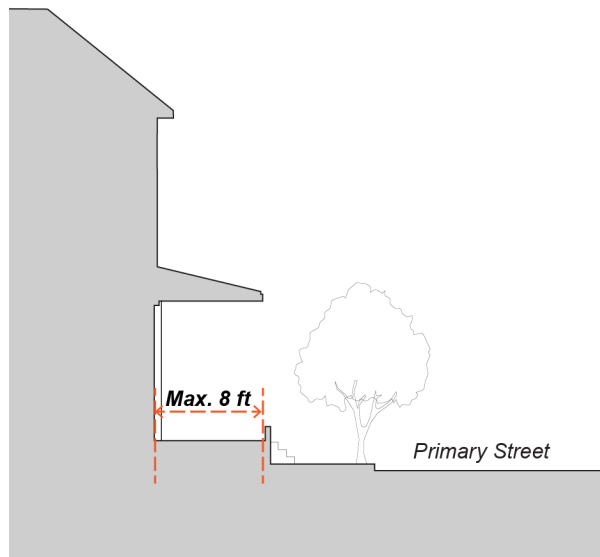

New Section 14.66.280 Design Standards Applicable to All Multi-Family and Residential Mixed-Use Development

A. Architectural Integrity.

1. Material palette on all floors above the ground floor, not including floors contained within a sloped roof form, must be consistent.
2. Change in material may occur only at the inside corner of a change in wall plane. Material must wrap around outside corners.

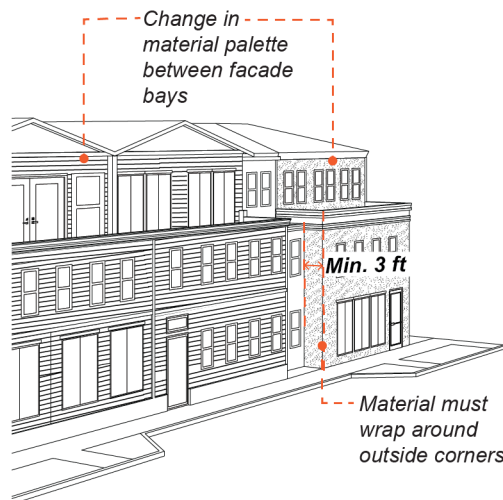

B. Firewalls and Visible Sidewalls.

1. Any exposed surfaces shall be consistent with and expressive of the overall building design and shall be finished in the same palette of materials as the rest of the building. Front façade finished materials, façade cornices, wall top projections, decorative details, and moldings must be carried and repeated on the side wall.
2. At least one of the following techniques must be employed on firewalls/visible sidewalls:
 - a. Incorporation of windows where code allows and adequate fire protection can be provided.
 - b. Gable and hip roofs to vary the height and appearance of sidewalls.
 - c. Inset panels.
 - d. Stepped-back front façade of upper floor(s) to vary the sidewall profile.

C. Durability. Exterior finish materials shall have an expected lifespan of no less than 30 years.

1. Features to direct rainwater away from exterior walls shall include one or more of the following:
 - a. Cornice, with drip at outer edge of corona (minimum 12-inch projection).
 - b. Projecting eaves (minimum 12-inch projection).

New Section 14.66.280 Design Standards Applicable to All Multi-Family and Residential Mixed-Use Development

- c. Scuppers, with or without downspouts (minimum 12-inch projection if no downspouts are used).
 - d. Gutters, with downspouts or rain chains.
 - i. Downspouts shall be one color and shall not change colors to match the wall behind them.
 - ii. Downspouts shall be round or rectangular, made of copper or metal.
 - iii. Downspouts shall not break façade profiles (such as a cornice) but shall wrap around projecting profile.
2. Exterior timber shall be protected from decay by one or more of the following:
- a. Material properties (e.g., cedar)
 - b. Staining and sealing
 - c. Painting
3. Exterior ferrous metals shall be protected from corrosion by one or more of the following:
- a. Metallurgical properties (e.g., galvanized, stainless, or weathering steel)
 - b. Painting or other impermeable coating.
4. **Windows.**
- a. All windows must be recessed a minimum of 3 inches from the outer wall surface for all Commercial and Multi-Family zones except the CT zone.
 - b. Window openings surrounded by masonry finish materials shall include a lintel that is taller than the sill/apron and proportional to the load it appears to carry.

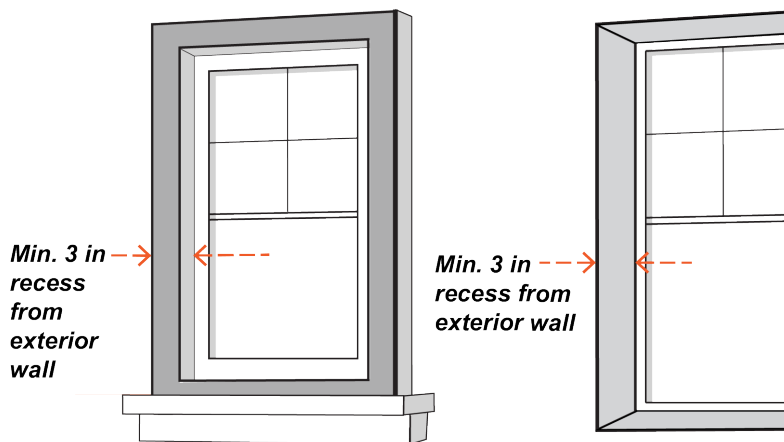

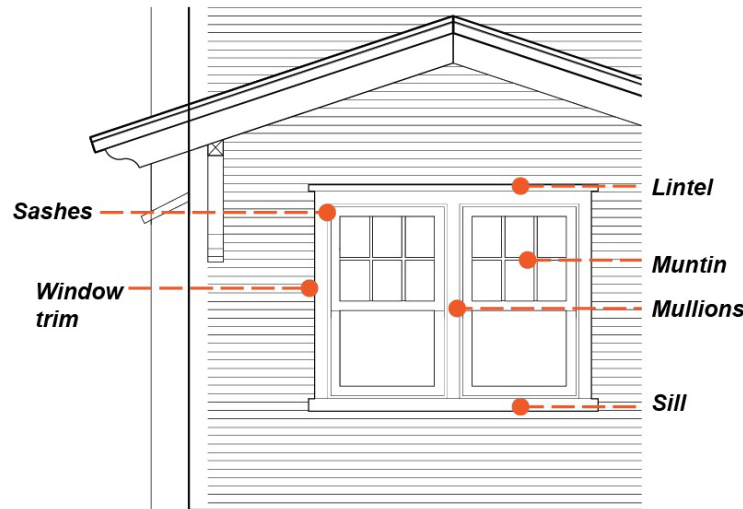

D. Materials. Materials shall appear only in places and configurations appropriate to their structural properties.

1. Where walls use masonry finish materials (e.g. stone, brick, CMU), any openings spanned by the material must be either:
 - a. Arched, with each arch defined by a continuous series of voussoirs and a single keystone at the apex; or
 - b. Rectangular, with a continuous lintel spanning the opening and extending beyond by 4 to 6 inches at each end. Vertical dimension of the lintel shall be no less than 1/8 of the clear span. Steel lintels are exempt from this minimum vertical dimension.
2. When used, exterior timber posts, beams, rafters, purlins, brackets, etc. shall be joined according to structural principles.
3. Where a change in material is desired, all façade materials shall turn the corner and terminate into a vertical element of the façade composition.
4. **Materials Defining Building Elements.**
 - a. *Base.* For multistory buildings, the base of the building shall be defined by a distinct material selected from among the following: Stone, brick, concrete, CMU, or stucco ("base material").
 - b. *Body.* Typical materials for the main body of the building include wood, fiber cement, brick, stone, or stucco. If brick is used, it must extend vertically to the base; if stone is used, it must extend vertically to the foundation.
 - c. *Parapet.* Parapets shall terminate in a parapet cap of stone, concrete, tile, metal, or molded stucco.
 - d. *Bays.* Horizontal changes in finish material shall occur at the boundaries between bays rather than within a bay.
 - e. *Arcades.* Arcades shall be supported by columns or piers in concrete/cast stone, fiberglass, or stucco. Archivolts and impostes shall be expressed using similar materials/appearance.

New Section 14.66.280 Design Standards Applicable to All Multi-Family and Residential Mixed-Use Development

- f. *Structural elements.* Structural elements visible on the building exterior (e.g. rafters, purlins, posts, beams, balconies, brackets, trusses, columns, arches, etc.), even when ornamental, shall be sized and spaced according to their corresponding structural role, and materials shall be selected accordingly (see A. Architectural Integrity).

5. **Materials Allowed for Building Details/Ornament.**

- a. Wood
- b. Metal (wrought iron, copper, aluminum, tin)
- c. Glass fiber reinforced concrete (GFRC)/fiberglass
- d. Terra Cotta
- e. Tile
- f. Plaster

E. Colors.

1. A maximum of 4 colors shall be applied to be the building façade:
 - a. 1 primary color comprising 50 percent or more of the façade excluding transparent surfaces.
 - b. 1 secondary color comprising no more than 30 percent of the façade excluding transparent surfaces.
 - c. 1 tertiary color comprising no more than 20 percent of the façade excluding transparent surfaces.
 - d. 1 accent color for use on trim and architectural details.
2. Materials with intrinsic, naturally-occurring coloration shall not count towards this maximum. Such materials are limited to copper, Corten steel, unpainted wood, tile, and brick. Materials with prefinished color (stucco, cement fiberboard, colorized metal) shall count towards the maximum.
3. Changes in color may occur:
 - a. To articulate changes between base, body, and top portions of a façade, which must be separated by a cornice or profile or a change in material and must remain consistent across the length of the façade bay.
 - b. When a portion of the elevation is articulated as a separate building with a break in the roof form and a step back in the façade plane 5 feet or greater or step up in façade height at least 10 feet.
 - c. On attached elements, such as bay windows, orioles, and balconies.

F. Façade Lighting. Façade lighting shall be incorporated into all storefront design and all facades facing an R-1 district. Fixtures shall be:

1. Shielded and directed onto the building facade.
2. Consistent in style with the primary building.

G. Habitable Outdoor Space. Private, habitable outdoor space supported by the building structure, such as balconies or terraces, shall be either uncovered or sheltered. The following patterns are strongly recommended:

1. **Pergola:** Posts supporting beams with brackets, which in turn support purlins and/or rafters. Posts shall be no narrower in any dimension than 3.5" or 1/20 of the unbraced post length, whichever is greater.
2. **Trabeation:** Posts or columns supporting beams with or without brackets, which in turn support either an additional floor level (for multi-story porches/balconies) or a full roof system based on rafters and/or purlins with decking and finish material. Posts shall be no narrower in any dimension than 3.5" or 1/20 of the unbraced post length, whichever is greater. The distance between posts shall be no wider than the total post height.
3. **Arcuation:** Encompassed by walls that are penetrated by arched openings bounded by either columns or piers. The ratio of column diameter [at lowest part of shaft] to column height shall be no less than 1:10 and no greater than 1:7. Width of piers at corners [abutments] shall be no less than 1/3 of the opening width; piers between multiple arched openings may be narrower.
4. **Rectilinear:** Bounded by square/rectangular piers framing rectilinear wall openings. If lintels are expressed on the facade, they shall extend over the piers by 4"-6" at each end. Piers shall be no narrower in any dimension than 15.5" or 1/6 of the opening width, whichever is greater. Piers at corners shall be wider than piers between openings.
5. **Fabric Shading:** Shaded by fabric elements such as awnings or stretched canvas, secured to the building structure, sheltered by Main Roof Form, supported by other building volumes.
 - a. Cantilevered balconies shall be secured architecturally to the wall below by brackets.
 - b. Bracket material shall be consistent with that of the balcony's floor structure.

H. Historic Preservation.

1. Additions to buildings with historic designation shall be identifiable from original construction. Additions shall employ similar or complementing materials and colors and shall exhibit similar opening proportions, facade rhythms and horizontal elements as the original.
2. Original transom windows shall be maintained or restored where possible. If the ceiling inside the structure has been lowered, the ceiling shall be stepped up to meet the transom so that light will penetrate building interior.
3. Deteriorated architectural features shall be repaired rather than replaced wherever possible. If replacement is necessary, new materials shall match the original in design, color, texture, and other visual qualities. If the original was painted, the substitute materials shall be painted as well.

I. Sustainability in Design.

New Section 14.66.280 Design Standards Applicable to All Multi-Family and Residential Mixed-Use Development

1. All new construction shall incorporate landscaping and fenestration to passively cool the building; energy-efficient HVAC; and energy efficient lighting.
2. All energy generation devices must blend in with the building color.
3. All on-site landscaping shall be drought-resistant and require minimal irrigation.

J. On-site landscaping.

1. Trees proposed within street-facing setbacks must be selected from the Los Altos Street Tree Planting List.
2. Trees planted on the south side of the building must be deciduous.
3. Species shall be selected and located according to direct sunlight needs.
4. Vegetation shall be installed along all exposed east and west facing walls.
5. Groundcovers shall be planted over a minimum 50 percent of landscaped areas to prevent ground reflection and keep surfaces cool.
6. When parking is tucked under a building, landscape planters must be provided to break up the continuous paving at the building's edge.

K. Screening.

1. Rooftop mechanical equipment must be screened from public view.
2. Barbed wire, chain-link, and razorwire are not permitted.

Content to be Added to 14.02.070 Definitions

“Board-formed concrete” means concrete that has textured patterns on its finished surfaces that retain the wood grain of boards or molds used to form the wet concrete.

“Chamfered corner” means a building corner which is cut back at a 45-degree diagonal from the primary façade to provide a corner surface at least 8 feet in length.

“Façade” means the exterior wall on any side of a building.

“Lined” parking refers to a building configuration where residential, commercial, or office uses are located between a street-facing property line and above-ground parking levels. Also referred to as a “wrapped” building.



Guido Persicone

From: Guido Persicone
Sent: Thursday, July 15, 2021 6:57 PM
To: Monica Szydlik; Drew
Subject: FW: Objective Design Standards

From: Jon Biggs <jbiggs@losaltosca.gov>
Sent: Thursday, July 15, 2021 4:35 PM
To: Guido Persicone <[gpsericone@losaltosca.gov](mailto:gpersicone@losaltosca.gov)>; Jolie Houston <jolie.houston@berliner.com>
Subject: FW: Objective Design Standards

FYI

From: Neysa Fligor <nfligor@losaltosca.gov>
Sent: Thursday, July 15, 2021 1:43 PM
To: Jon Biggs <jbiggs@losaltosca.gov>
Cc: Brad Kilger <bkilger@losaltosca.gov>
Subject: Fw: Objective Design Standards

FYI.

Best,
Neysa

From: Mehruss Jon Ahi <mahi@losaltosca.gov>
Sent: Wednesday, July 14, 2021 9:35 AM
To: Neysa Fligor <nfligor@losaltosca.gov>
Subject: Objective Design Standards

Dear Mayor Fligor,

Hope you are doing well. I just realized that the Council discussed the Objective Standards last night with various new edits. I understand that some edits are to be expected with a document of this nature but I'm a little concerned about some of the late additions. I've listed them below, along with my opinion on it. Overall, I believe that there are too many subjective additions and also certain items that should not have been changed from the previous version.

1. Privacy and Line of Sight (Most Zones)

Comment: The new comments discuss creating an angled window at 30 degrees for bedroom windows, measured at the adjacent side setback line. As an architect, I believe that this would be subjective to require windows to be angled in such a way. Not only would you be losing square footage by angling the window out or in, but there wouldn't be an objective reason to make such a requirement. Instead, you could make the window opaque or make sure that windows are pushed farther in (more articulation), but to angle them at an arbitrary number seems odd. A slightly angled window would not help solve the privacy issue with an adjacent neighbor. It would simply just be a temporary solution.

2. Site Circulation and Access (CT)

Comment: For this section, it says that a “continuous bicycle/pedestrian only access shall be provided along the rear setback on all lots where development abuts an R-1 district to the rear”. I think that the word “continuous” might make things confusing because it is unclear if we would want a dedicated path in the rear that wraps to the front or just an accessible point. This may cause issues because we could possibly be requiring a continuous access in the entire rear setback when that’s not always possible for every project.

3. Upper Story Stepbacks (CT and CD-R3)

Comment: These sections had been changed from a building stepping back on the 5th Level or 4th Level to stepping back at 45’-0” or 35’-0”. I’m not sure who proposed this change, but having the stepback occur at an arbitrary height is not wise. There are 2 projects in particular (5150 El Camino and 4350 El Camino) where the top of the 4th Level actually occurred lower than 45’-0”. So essentially, we would be telling Developers to go up to 45’-0” and then step back, when in reality, they might have gone lower to begin with. My other concern is the fact that a CT Development may incorporate Ground Floor Commercial at some point and the height from ground level to the 4th Floor would be very different than a purely residential building so we cannot just incorporate a random height number to trigger the stepback. I feel very strongly that this should go back to Levels and not a Height Number.

4. Downtown Gateways Section

Comment: The entire Downtown Gateways Section is entirely too subjective for this document. Items such as “Special uses with outdoor plaza” and “Special landscape features” only add more confusion for development projects because they are not specific and not intentional. My understanding was that these standards were not supposed to include specific language for precise areas. It does not sit well with me because it feels like we are taking from our other documents (Downtown Design Guidelines, Downtown Vision, etc.) and trying to fit them into this, when all along, this was always about the objective design standards and not about any Gateway between Edith Avenue, State Street and San Antonio Road. The Planning Commission made sure to not include this in our analysis so this feels misplaced. I think it’s only a matter of time until this section gets taken out because of the confusion it will cause with Architects and Developers who are misunderstanding what each element really means.

Those were all the items I caught but I’m hoping that these can be figured out before the document gets passed. I’m available if you’d like to discuss any of these items more thoroughly or have any questions.

Thanks,
Mehruess Ahi

Mehruess Jon Ahi
Planning Commissioner
City of Los Altos
mahi@losaltosca.gov
(650) 208-1140

Corrections, inconsistencies, and questions regarding Objective Standards

(Compiled by Vice Mayor Enander and includes input from Council member Lee Eng and resident Jon Baer).

CONTENT / POLICY ISSUES

1. Inconsistent diagrams and descriptions regarding front setbacks

Goal: text and diagrams should be consistent within and between sections and with other height standards. They should be clear enough to avoid potential misinterpretation based on omissions or ambiguities.

- a. The objective height limits for CN, CD, CRS, CD/R3 (commercial/mixed-use) and CRS/OAD are all 30' (35' for all residential in CD/R3). What is the rationale for having the set-backs and roof form requirements referenced to that 30' for CD and CD/R3 but to "stories" for the others? If the assumption is that the third story will always intercept the height limit, why not use the height limit numerically and provide a reference line on all diagrams? Or simply require everything above 2 stories to be set back according to the requirements.
- b. If we stick with describing height in feet, then as CD/R3 is 30' for commercial or mixed use but 35' for all residential, it would be useful to add a dashed red line at 35' to the diagram below A.1.c.
- c. The CN, CRS, and CRS/OAD all give the option regarding third stories either to setback by a specific minimum number of feet or to embed in the roof form. CD and CD/R3 do NOT give an option to embed the third story in the text (compare the A.1.a for the various zones, except that for CN it is B.1.a.) but DO use the SAME diagrams as the other zones (CN, CRS, CRS/OAD), all of which (3rd from left) are captioned "3rd story embedded in a sloped roof form." If it is the intention that in CD and CD/R3, the standards would allow a third story to be embedded in a sloped roof form rather than set back, the text should be changed to read as it does for the other zones so as not to present an image that does not match text. Otherwise, the diagrams for CD and CD/R3 should be changed.
- d. It is unclear in the text for CD and CD/R3 that the requirement to step back the floor that intercepts that height limit requires the entire floor – to the floor plate – to be stepped back. The diagram implies as much, but the text is not explicit.
- e. It is implied via the diagrams, but not explicitly stated in the text, that any building over 3 stories must have the 3rd story stepped back AND have the

“uppermost” story set into one of the specific roof forms. Text should be explicit that both apply. Also, why not say 4th story (if we are sticking with stories?) rather than “uppermost.”

- f. There is nothing in text or diagrams to deal with the possibility of a 5-story building. Are we confident there can't be such? If there is, what setback is required on the 4th story?

2. Policy questions: What are we losing / gaining?

- a. A quick review of buildings approved in the CT and CD/R3 zone during the past 4-5 years shows that none would likely conform to the basic massing and articulation standards. This raises two issues: (1) are we losing some building styles or elements that we actually like? (2) should we create a legal carve-out for these recent buildings so that they do not become “legal non-conforming” but are excepted from those requirements?
- b. If all 4-story buildings have to have the 4th floor embedded in the sloping roof form, is the likely result to be a very high percentage of buildings with mansard roofs? Is this a desirable outcome of the standards?

3. Ground Floor Floor-to-Ceiling Height (CN, CRS, CT, CD/R3, CRS/OAD)

14.40.150.C.3.b (CN) - there is no requirement in the current code for the first floor to be 12' in CN as there are with other zones.

Why, therefore, is the same language and associated diagram included here as is found in the other zones that do have such a requirement? I thought we weren't changing/adding objective standards elsewhere. If this stands, it would be ambiguous or in conflict with 14.40.140.

- b. The converse applies to 14.44.130 (CD). The zoning code at 14.44.120 requires a minimum interior ceiling height of 12', but there is no similar language or diagram in the proposed 14.44.130 Design Control document.

c.

4. Building materials - definition of “primary”

- a. May need to adjust definitions to specify how glazed surfaces (fenestration) is included in the calculation. If determination of primary/secondary are

meant to be calculated on the façade net of fenestration, this should be specified.

5. Breaking up facades (example for CT at B.2.a. but found elsewhere)

- a. Requirement to break up facades of more than x length must be “defined by a recess a minimum of 3 feet deep.” Why is there no minimum width? It seems there should be a minimum as maximum for both primary and secondary to prevent “striped” buildings – or are all primary facades 50 feet by definition?

6. Deleted reference to landscaping on blank walls still on graphic

- a. Policy question: Why was the requirement to “enhance” blank walls deleted?
- b. If intentional, then at CD - 14.44.130.B.1. – old item c was deleted – the accompanying diagram that follows, primarily to portray transparency requirements, still has the text annotation of the now-deleted requirement (“Blank walls at the ground level must be enhanced with architectural details, landscaping...”). If deleting that was council direction, then the requirement should be removed from the graphic.
- c. Make same change in CRS, CT, CRS/OAD re: diagram. If text is restored, please note the text was also deleted in CD/R3 at B.1.c, although there was never a diagram. And for CRS, the wording was at the bottom of the page after B.1.b.vi. is apparently in an errant place.

7. 14.24.110 (R3-1) apparent inconsistency

- a. Is there some logic to having B.1.a, B.1.b, and B.2 reference requirements if facades are greater than 50 feet, but in B.3 the requirements apply if the façade is over 48 feet? Why aren’t all the same (either 48 or 50)?

EDITORIAL FIXES

8. Reference errors:

- a. 14.40.150 B.1.a change “Section A.7” to “Section B.7-There is no
- b. 14.54.130 A.1.b change “Section A.7” to “Section A.6”

9. Caption errors

- a. 14.44.130 (CD) A.1.a. required 10 foot upper-story step back. Caption on the diagram says 5 feet.

b. 4.52.110 (CD/R3) has the same error.

10. Window sill height

- a. CN B.6.b. - why "maximum" sill height? Should be "minimum"?
- b. Also in CRS, CT, CD/R3, CRS/OAD,

11. CN - C.4.a re: Interior Courtyard

- a. I think there's a pair of words reversed. It reads "...must be: Partially visible from the street and linked to the street by clear a circulation element." I think the words "clear" and "a" are reversed. I don't claim to know what this really means, however.

From: [Jon Biggs](#)
To: [Guido Persicone](#); [Monica Szydlak](#); [Drew](#)
Subject: FW: Objective Standards input
Date: Monday, July 26, 2021 3:36:08 PM

FYI - input from Councilmember Lee Eng.

Jon

-----Original Message-----

From: Lynette Lee Eng <lleeeng@losaltosca.gov>
Sent: Monday, July 26, 2021 12:10 PM
To: Jon Biggs <jbiggs@losaltosca.gov>
Cc: Gabriel Engeland <gengeland@losaltosca.gov>
Subject: Objective Standards input

Hi Jon,

Just wanted to follow up on the input you requested. Here are a few of my suggestions:

- Definitions - we need to make it easy to understand what we clearly mean. (E.g. - sloped roof, what we expect and does 1% slope mean a slope we are willing to accept or the other extreme (89%), both unacceptable) I believe we need to define the acceptable range.

We need to make sure that if we have things come before us on an appeal and can defend ourselves. Clearly describing how we measure and will look at things (e.g. - Finished height and width, and what we mean.)

- (pg. 8) - Trellis and landscaping - there should be a method to provide adequate lighting and maintenance.

- (p. 34) Replace the blank wall restriction.

- (p. 103) Clean up of the different heights mentioned.

-(p. 124) We need to break down each of the elements of Architectural integrity. The elements should be clearly articulated, defined, and made easy to understand to make it somewhat objective.

- Architectural Style - We are too vague. (E.g. - for downtown we should be clearly emphasizing the Downtown Building Guidelines)

- (p.78) Underground garages require a warning system and can only be waived if staff determines that due to the specifics of the location that it will not be required.

Thanks,
Lynette Lee Eng

From: [Neysa Fligor](#)
To: [Jon Biggs](#); [Guido Persicone](#)
Subject: 7/13/21 Objective Standards Notes/Comments
Date: Monday, August 2, 2021 8:12:05 AM

Hi Jon and Guido,

Here are the notes I made on the draft Objective Standards from our 7/13 meeting. I don't view these as substantive/material changes. I have not compared them to the discussion at the meeting so some of these may have already been addressed. Also, some of my comments apply to other sections that have similar language. Thanks.

General comments:

- Can we label the different diagrams?
- Can we add the code in the footer or header of each page so we know what code section we are reviewing? Kept flipping back/forth to see what section I was reviewing.
- I like the diagrams that have the check for acceptable and X for not acceptable

14.40.150 (CN)

-B1. Because it says "except El Camino Real" in a couple places, should we add a sentence that points the reader to where the requirements for El Camino are? For eg, please see [_____] for El Camino Requirements.

-B1a - should be B7 not A7

-B1a and 2a: Can we add "For three-story buildings. . ."

B2b - should it also say that the third story should be set back to align with the uppermost story?

B4b-I think its better to refer to section B7 instead of just saying roof form

B6 - The original wording was fine except for the 12 inches requirement. The new language also seems to be saying something different from what's crossed out.

B7 - Comment --Interesting re Fremont Avenue

C2c- Comment/Question-why deleted?

E1- Are there other acceptable types of siding materials? It says all siding must be wood, composite wood or cement fiberboard, but then excludes vinyl and aluminum. Its either we don't need to exclude vinyl/aluminum if only wood, etc are allowed, or we state everything is allowed except vinyl and aluminum.

E- why was this section on open space deleted? Can we reinstate?

14.48.130 (CRS)

B4- Does it matter if its non residential vs residential for the floor to floor ceiling height?

F5- assume those separate sections cover fast growing, etc

14.50.170 (CT)

H- Worded differently from a previous section that used the word Lined. Intentional?

14.52.110 (CD/R3)

B2f - I thought we talked about changing it to require 2 or more standards for the street facing entries.

14.54.130 (CRS/OAD)

-A1a and b - Should it be A6?

-B1 - Should it be 50 and not 25 foot module?

B1 - Change second "a" to "b"

-E - should be gateway, not gateways

Best,

Neysa

14.44.130 CD

-B3h - Comment/Question - why deleted?



MEMORANDUM

DATE: August 11, 2021

TO: City Council

FROM: Guido F. Persicone, Planning Manager
Jon Biggs, Community Development Director

SUBJECT: RESPONSE TO COMMENTS-OBJECTIVE STANDARDS PROJECT

Commentor: Mehruss Ahi, Architecture Designer¹

1. Privacy and Line of Sight (Most Zones)

Comment: The new comments discuss creating an angled window at 30 degrees for bedroom windows, measured at the adjacent side setback line. As an architect, I believe that this would be subjective to require windows to be angled in such a way. Not only would you be losing square footage by angling the window out or in, but there wouldn't be an objective reason to make such a requirement. Instead, you could make the window opaque or make sure that windows are pushed farther in (more articulation), but to angle them at an arbitrary number seems odd. A slightly angled window would not help solve the privacy issue with an adjacent neighbor. It would simply just be a temporary solution

Staff/Consultant Response: The specific numerical value of the angle makes this an enforceable, objective standard. Requiring articulation would result in the same issue (loss of square footage). Per comment, an opaque window is a good option as well.

Recommended revised text:

- Primary living spaces and balconies located along a side setback shall orient principal windows and balconies toward the front and rear of the building.
- Where windows are within 10 feet of and oriented toward an interior side setback, glazing shall either be a minimum 30-degree angle measured perpendicular to the adjacent side setback line, have minimum sill height of 42 inches, or be opaque.
- The maximum sill height for an ingress/egress window is 44 inches from finished floor.

¹ Planning Commissioner Ahi is an architectural designer and he sent the city his personal comments. It is important to note these edits do not reflect the position of the Planning Commission, which recommended approval of the Objective Standards in January of 2021

A.

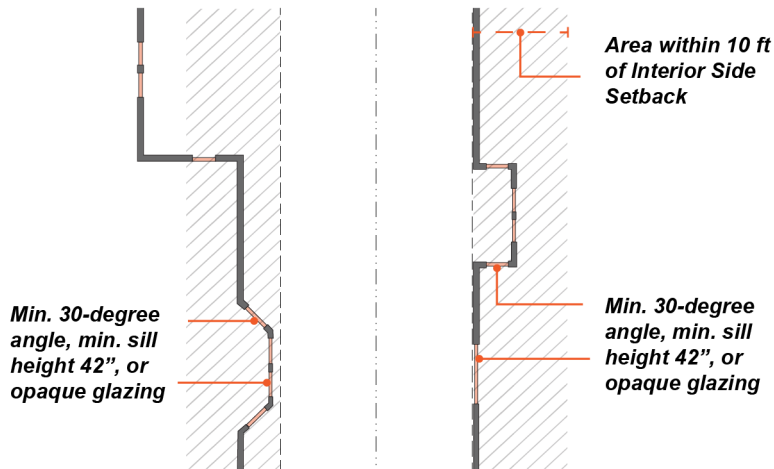

Commentor: **Mehruss Ahi, Architecture Designer**

2. Site Circulation and Access (CT)

Comment: For this section, it says that a “continuous bicycle/pedestrian only access shall be provided along the rear setback on all lots where development abuts an R-1 district to the rear”. I think that the word “continuous” might make things confusing because it is unclear if we would want a dedicated path in the rear that wraps to the front or just an accessible point. This may cause issues because we could possibly be requiring a continuous access in the entire rear setback when that’s not always possible for every project.

Staff/Consultant Response: The community expressed a desire that continuous pedestrian and bicycle access be developed over time along the rear of the CT district where parcels are deep and where the corridor abuts low-density residential. This is so that residents can comfortably access the new development from the rear/ away from El Camino Real.

Recommended edits:

CT: “Rear pedestrian/bicycle access shall be provided from any abutting right-of-way or alley for projects: (no edits to a and b)”.

CN: H.3 deleted.

Page: 40

I. Site Circulation and Access

1. New development on abutting lots shall be designed to allow cross-access for internal pedestrian, bicycle, and vehicular circulation systems.
2. Bicycle racks shall be provided:
 - a. In or within 50 feet of every parking area; and
 - b. Within 20 feet of at least one building entrance.
3. Continuous bicycle/pedestrian-only access shall be provided along or within the rear setback:
 - a. On all lots with a depth of 250 feet or greater; and
 - b. On all lots where development abuts an R-1 district to the rear.

Commentor: Mehruss Ahi, Architecture Designer

3. Upper Story Stepbacks (CT and CD-R3)

Comment: These sections had been changed from a building stepping back on the 5th Level or 4th Level to stepping back at 45'-0" or 35'-0". I'm not sure who proposed this change but having the step back occur at an arbitrary height is not wise. There are 2 projects in particular (5150 El Camino and 4350 El Camino) where the top of the 4th Level actually occurred lower than 45'-0". So essentially, we would be telling Developers to go up to 45'-0" and then step back, when, they might have gone lower to begin with. My other concern is the fact that a CT Development may incorporate Ground Floor Commercial at some point and the height from ground level to the 4th Floor would be very different than a purely residential building so we cannot just incorporate a random height number to trigger the stepback. I feel very strongly that this should go back to Levels and not a Height Number.

Max Height allowed in the CT Zone: 45 Feet

Max Height allowed in the CD/R3 Zone: 30 feet-commercial/mixed use/35 feet-residential²

Pages: 40 (CT), 53 (CD/R3)

Staff/Consultant Response: CD and CD/R3 districts: As noted, this step-back was changed from being required at the 4th story to being required above the max base height (which is 30 or 35ft, depending on use). Diagrams in previous drafts indicated this intent by showing the stepped-back portion dotted-in above the base height limit. However, diagrams of previous drafts also showed 3 stories fitting within the base height limit, which is possible, but not typical. The revised standard addresses this fact and shows diagrams that more accurately reflect what will be built. In addition, the revised standard does still allow three stories with no required step-back, provided it does not exceed the base height limit

² CD/R3-No commercial or mixed-use structure shall exceed thirty (30) feet in height and no entirely residential structure shall exceed thirty-five (35) feet in height.

Revised 14.52.110 Design Control (CD/R3)

A. Building Massing and Articulation.

1. Upper-story Step-backs

- a. *Front:* Minimum 10 feet from ground floor façade above 30 feet in height (commercial or mixed use) or 35 feet (residential only).
- b. *Street Side:* Minimum 10 feet from ground floor façade above 30 feet in height (commercial or mixed use) or 35 feet (residential only).
- c. For buildings over three stories, the uppermost story must be embedded in a sloped roof form such as a mansard roof or a hipped and/or gabled roof with dormers, as allowed by standards in Section A.6.

CD:

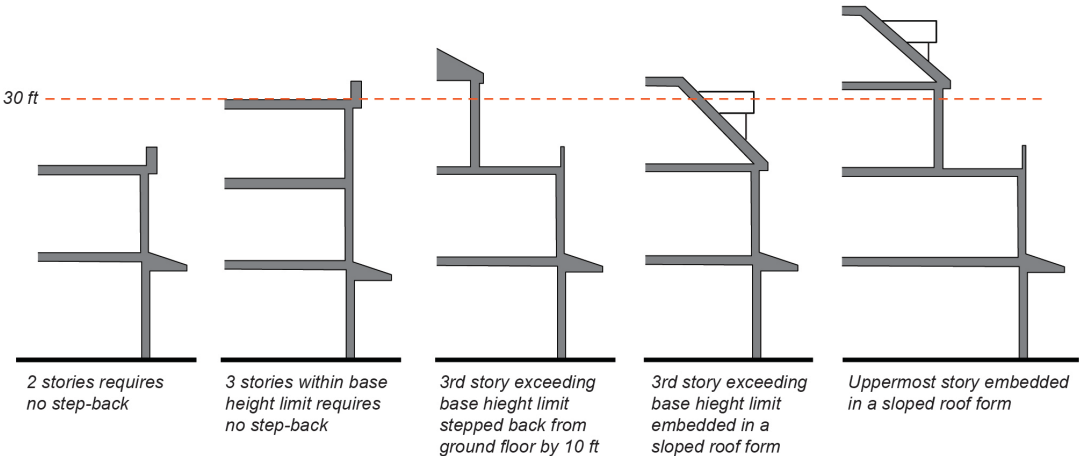

CD/R3:

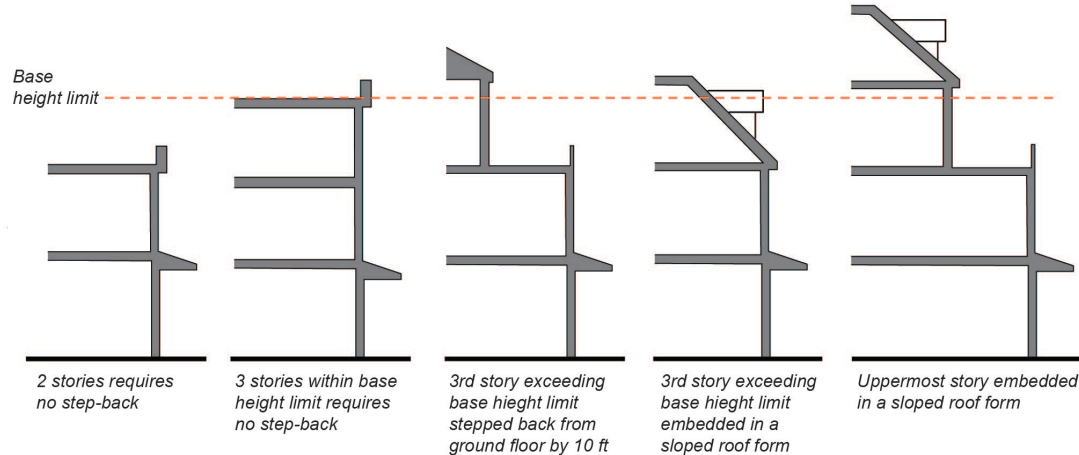

Revised 14.50.170 Design Control (CT)

- A. Building Placement.** A minimum 75 percent of ground-floor building frontages facing El Camino Real must be built at the minimum setback line. This standard applies to the building frontage only (exclusive of side setbacks).
- B. Building Massing and Articulation.**
1. **Upper-story Step-backs.**
 - a. *Front:* Minimum 10 feet from ground floor façade above 45 feet in height.
 - b. *Street Side:* Minimum 10 feet from ground floor façade above 45 feet in height.
 2. **Vertical Articulation**

Staff/Consultant Response: CT district: Same logic as above but with 5th story / 45 ft base height limit. No edits recommended.

Commentor: Mehruss Ahi, Architecture Designer

4. Comment: The entire Downtown Gateways Section is entirely too subjective for this document. Items such as “Special uses with outdoor plaza” and “Special landscape features” only add more confusion for development projects because they are not specific and not intentional. My understanding was that these standards were not supposed to include specific language for precise areas. It does not sit well with me because it feels like we are taking from our other documents (Downtown Design Guidelines, Downtown Vision, etc.) and trying to fit them into this, when all along, this was always about the objective design standards and not about any Gateway between Edith Avenue, State Street and San Antonio Road. The Planning Commission made sure to not include this in our analysis so this feels misplaced. I think it’s only a matter of time until this section gets taken out because of the confusion it will cause with Architects and Developers who are misunderstanding what each element really means.

Staff/Consultant Response: Recommended edit:

1. Building design at gateway intersection shall include:
 - a. Façade lighting; and
 - b. Overhangs or sloped roof forms.
2. Ground-floor design at gateway intersections must address both street frontages through:
 - a. Entrances that are visible and directly accessible from both streets;
 - b. Building transparency beyond the required minimum for the first 15 feet of building frontage from the corner;
 - c. Landscaped area with a minimum dimension of six feet; and
 - d. A usable public space with pedestrian-scaled features.

- E. **Downtown Gateways.** A **downtown gateway** is located at the intersection of Foothill Expressway at Main Street.
1. A minimum two elements from the following list must be incorporated into corner building design at gateway intersections:
 - a. Sloped roof structures
 - b. Special uses with outdoor plaza
 - c. Special landscape features
 - d. Enhanced on-site lighting
 - e. Increased architectural details
 2. Ground-floor design at gateway intersections must address both street frontages through:
 - a. Entrances that are visible and directly accessible from both streets
 - b. Building transparency beyond the required minimum for the first 15 feet of building frontage from the corner
 - c. A usable public space with pedestrian-scaled features on the non-entrance street.

Commentor: Councilmember: Councilmember Lee Eng/Vice Chair Vice Chair Enander

5. Comment: A quick review of buildings approved in the CT and CD/R3 zone during the past 4-5 years shows that none would likely conform to the basic massing and articulation standards. This raises two issues: (1) are we losing some building styles or elements that we actually like? (2) should we create a legal carve-out for these recent buildings so that they do not become “legal non-conforming” but are excepted from those requirements?

Staff/Comment Response: The objective standards under consideration are the product of community input, feedback from decision makers, stakeholders, public comment made at planning commission meeting, Planning Commissioner input, and a review of the various regulations and policy documents, and various existing buildings that are currently in place. These standards are an effort to synthesize all of this information and input and it is an effort to bring together the best of what was learned.

The subjective and objective design review processes are two different types of reviews that are used to evaluate the design of a project. In the subjective, the discretion of the decision makers weighs heavily in the final decision of a project whereas in the objective design review process, a project’s design is measured against a set of standards. If there are certain building styles or elements that members of the City Council believe are missing or need to be addressed, these should be brought up and explained along with potential language modifications to the code that will achieve the desired project design.

In terms of nonconformity, this has been discussed previously at other city council meetings and the initial direction provided by the Council was that if more than 50% of the existing floor area or any façade of a building not approved through the objective design standards process, then the entire building would have to be brought into compliance with the adopted objective standards.

Commentor: Councilmember Lee Eng/Vice Chair Enander

6. Comment: If all 4-story buildings have to have the 4th floor embedded in the sloping roof form, is the likely result to be a very high percentage of buildings with mansard roofs³? Is this a desirable outcome of the standards?

Staff/Consultant Response: Not necessarily. This standard is meant to apply in instances where a qualifying project uses State Density Bonus Law to exceed the maximum allowed height set by the base zone. The top-floor standard has been included to minimize the perceived height of buildings that exceed the maximum height allowed by the base zone and can be accommodated by gable and hipped roof forms with a variety of dormers that help to break up the roof expanse and provide useable floor space. If mansard roofs are not desirable, the code could be modified to prohibit them.

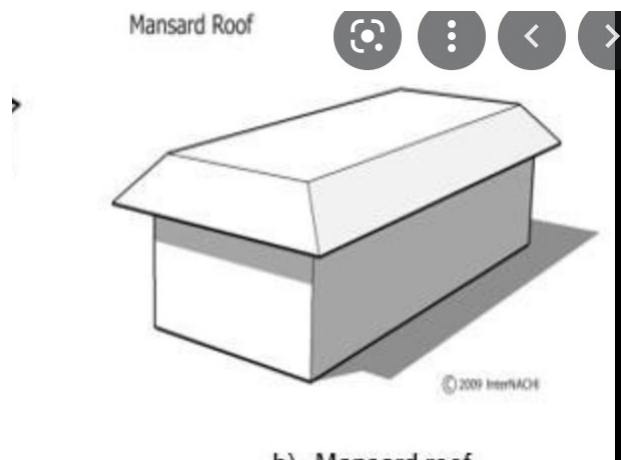

Commentor: Councilmember Lee Eng/Vice Chair Enander

7. Comment: there is no requirement in the current code for the first floor to be 12' in CN as there are with other zones. Why, therefore, is the same language and associated diagram included here as is found in the other zones that do have such a requirement? I thought we weren't changing/adding objective standards elsewhere. If this stand, it would be ambiguous or in conflict with 14.40.140.

Staff/Consultant Response: This standard is independent of any existing height standards – instead, it is intended to provide a hierarchy relationship between the ground floor and the upper floors. It is up the architect and developer to develop a plan that complies with this standard in addition to complying with the height limit.

14.40.140 - Height of structures (CN).

No structure shall exceed thirty (30) feet in height.

³ A mansard or mansard roof is a four-sided gambrel-style hip roof characterized by two slopes on each of its sides with the lower slope, punctured by dormer windows, at a steeper angle than the upper.

3. **Ground Floor Floor-to-Ceiling Height.**
- Minimum 24 inches taller than typical upper floor floor-to-ceiling height where **ground floor** is non-residential.
 - Minimum 12 inches taller than typical upper floor floor-to-ceiling height where **ground floor** is residential.

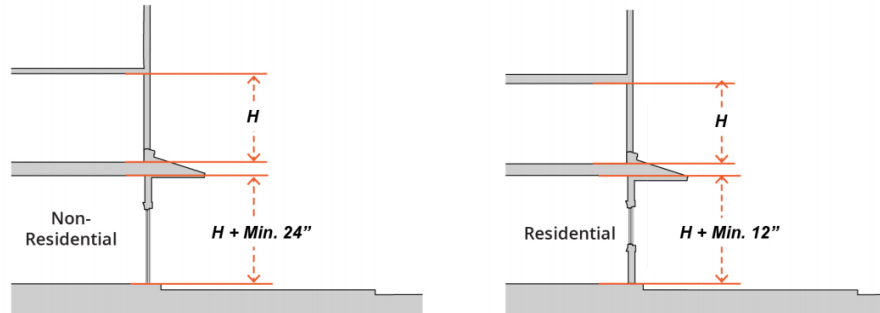

Commentor: Councilmember Lee Eng/Vice Chair Enander

8. Comment: The converse applies to 14.44.130 (CD). The zoning code at 14.44.120 requires a minimum interior ceiling height of 12', but there is no similar language or diagram in the proposed 14.44.130 Design Control document.

Staff/Consultant Response: Currently in the CD section of the code a max height of 30 feet is listed with an additional caveat that the minimum interior ceiling height of 12 feet be included to accommodate retail uses. The commentor is correct that the requirement for additional ceiling height is not included in the draft objective standards. Agreed, this should be included in the CD. Documents edited accordingly.

14.44.120 - Height of structures (CD).

No commercial or mixed-use structure shall exceed thirty (30) feet in height. The first story shall have a minimum interior ceiling height of twelve (12) feet to accommodate retail use, and the floor level of the first story shall be no more than one foot above sidewalk level.

Commentor: Councilmember Lee Eng/Vice Chair Enander

9. Comment: Does using upper floor heights as the reference by which first floor heights are determined allow for any undesirable consequences?

Staff Response: I think the commentor is asking the following question:

“If we mandate that the first floor be 24 inches taller than a normal “floor” per the objective zoning standards, are we inadvertently creating a scenario by which developers would be able to automatically get increased height for a building?” No, an applicant would still have to make the case for getting a density bonus concession or waiver by the specific legal thresholds identified in Density Bonus Law.

elements are exempted.

3. **Ground Floor Floor-to-Ceiling Height.**

- a. Minimum 24 inches taller than typical upper floor floor-to-ceiling height where ground floor is non-residential.
- b. Minimum 12 inches taller than typical upper floor floor-to-ceiling where ground floor is residential.

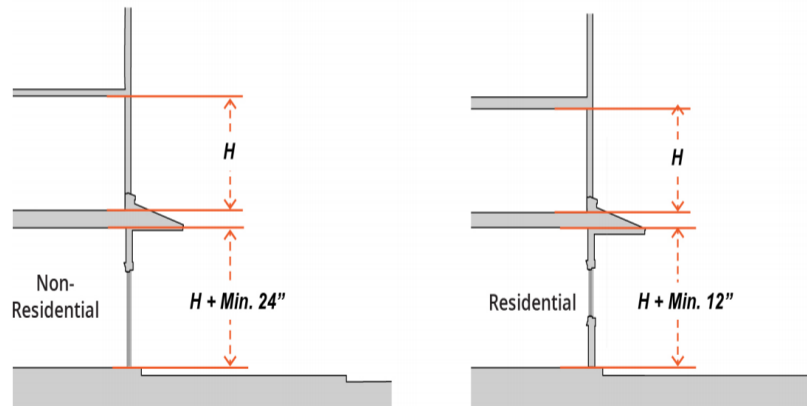

4. **Interior Courtyard.** Interior courtyards must be:

- a. Partially visible from the street and linked to the street by clear a circulation element.

Commentor: Councilmember Lee Eng/Vice Chair Enander

10. Comment: Building materials – definition of “primary” May need to adjust definitions to specify how glazed surfaces (fenestration) is included in the calculation. If determination of primary/secondary are meant to be calculated on the façade net of fenestration, this should be specified.

Staff Response: There are a few very good questions within this comment. First is the definition of what is considered the “primary” or “front”? This is actually codified already in the Los Altos Zoning Code, and it should not be changed as part of this process because it clearly defines the front lot line.

"Front lot line" means, on an interior lot, the lot line abutting a street, or, on a corner lot, the shortest dimension of the lot fronting the street, or, on a double frontage lot, the lot line abutting the street providing the primary means of access to the lot, or, on a flag lot, the interior lot line most parallel to and nearest the street from which the means of access is obtained, except that where the average width of a flag lot exceeds its average depth and the longer dimension is considered the depth, the front lot line will be the property line from which the front yard is measured. On a corner lot, if

more than one property line abutting on a street can be designated as a front lot line without creating a nonconforming lot or structure, then either property line may be deemed the front lot line⁴.

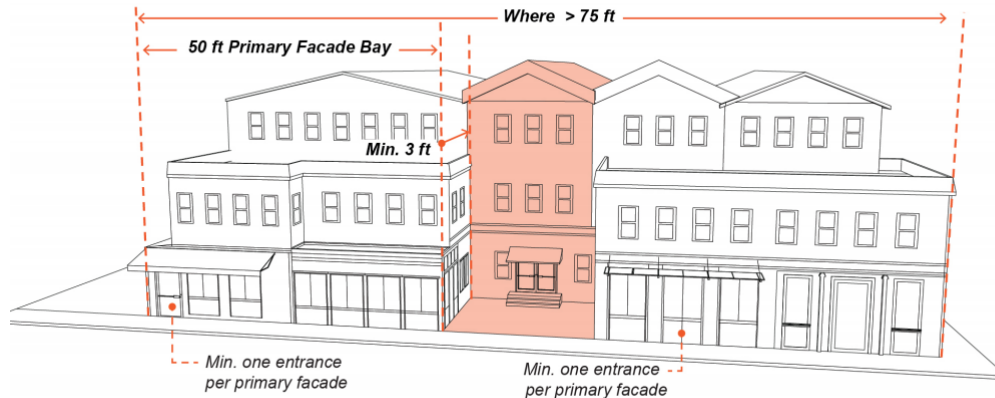

The second part of the comment really speaks to what is the “front façade” but even this is clearly articulated in the draft Objective Standards document meaning the primary architectural element of the building and is generally shown in lineal feet.

Recommended edits to Building materials standards:

- Primary shall mean 50 percent or more of a façade surface area excluding transparent surfaces. The following primary cladding materials are allowed:
- Secondary shall mean less than 50 percent of a façade surface area excluding transparent surfaces. The following secondary cladding materials are allowed:

Recommended edits to Definitions:

- “Façade” means the exterior wall on any side of a building.

Commentor: Councilmember Lee Eng/Vice Chair Enander

11. Comment: Breaking up facades (example for CT at B.2.a. but found elsewhere). Requirement to break up facades of more than x length must be “defined by a recess a minimum of 3 feet deep.” Why is there no minimum width? It seems there should be a minimum as maximum for both primary and secondary to prevent “striped” buildings – or are all primary facades 50 feet by definition?

Staff/Consultant Response: City staff and the consultant are unclear about this comment because the CT design controls and the diagram within the document clearly articulate that after 50 feet the architect will be required to break up the massing with a three (3) foot recess. Width is not specified because the articulation can simply be a change in plane.

⁴ This section is from the Definitions sections of the Zoning Ordinance (see 14.02.070)

b. Street level minimum 10 feet from ground floor façade above 10 feet in height.

2. **Vertical Articulation.**

- a. When a building façade exceeds 100 feet in length along a right of way, it must be separated into primary façade bays no greater than 50 feet and secondary façade bays defined by a recess a minimum of 3 feet deep.
- b. A minimum one entrance shall be provided per 150 linear feet along El Camino Real and per primary façade bay along all other rights-of-way.
- c. The eave/roof of a secondary façade bay shall be no higher than the corresponding elements of the primary façade bay.



Commentor: Councilmember Lee Eng/Vice Chair Enander

12. Comment: Why was the requirement to “enhance” blank walls deleted? If intentional, then at CD - 14.44.130.B.1. – old item c was deleted – the accompanying diagram that follows, primarily to portray transparency requirements, still has the text annotation of the now-deleted requirement (“Blank walls at the ground level must be enhanced with architectural details, landscaping...”). If deleting that was council direction, then the requirement should be removed from the graphic⁵.

Staff Response: This was not deleted, only moved to accommodate other changes requested. See B.1.A.iv.

⁵ CD Design Controls, page 19 of the document.

B. Building Design.

1. Façade Design.

- a. Building facades must continue the pattern established by existing buildings in Downtown Los Altos by reinforcing the underlying maximum 50-foot module along all street frontages through the use of the following techniques:
 - i. Building facades shall be arranged in an orderly composition of bays, defined by vertically aligned openings alternating horizontally with solid walls or columns. The pattern shall be visually expressed through the spacing of openings, recesses, eaves, inset panels, cornices, overhangs, trellises, exposed rafters, columns, or bay windows.
 - ii. The pattern may be shared between the ground floor and upper stories provided the ground floor exhibits enhanced detail or modulation.
 - iii. Residential facades shall incorporate at least one element that signals habitation, such as bay windows, or balconies.

Draft Los Altos Objective Design Standards | 19

- iv. Non-glazed wall areas (**blank** walls) at the ground level must be enhanced with architectural details, landscaping, and/or landscaped trellises or lattices.

Commentor: Councilmember Lee Eng-Vice Chair Enander

13. Comment: Make same change in CRS, CT, CRS/OAD re: diagram.

13a-If text is restored, please note the text was also deleted in CD/R3 at B.1.c, although there was never a diagram.

Staff Response: Once again, city staff are unclear about this comment because within the CD/R3 design controls blank walls must show some architectural details and/ landscaping.⁶

⁶ See page 58 of the document for further details.

B. Building Design.

1. Façade Design.

- a. Building facades must continue the pattern established by existing buildings in Downtown Los Altos by reinforcing the underlying maximum 50-foot module along all street frontages through the use of the following techniques:
 - i. Building facades shall be arranged in an orderly composition of bays, defined by vertically aligned openings alternating horizontally with solid walls or columns. The pattern shall be visually expressed through the spacing of openings, recesses, eaves, inset panels, cornices, overhangs, trellises, exposed rafters, columns, or bay windows.
 - ii. The pattern may be shared between the ground floor and upper stories provided the ground floor exhibits enhanced detail or modulation.
 - iii. Residential facades shall incorporate at least one element that signals habitation, such as bay windows, or balconies.
 - iv. Non-glazed wall areas (**blank** walls) at the ground level must be enhanced with architectural details, landscaping, and/or landscaped trellises or lattices.

13b. Comment: And for CRS, the wording was at the bottom of the page after B.1.b.vi. is apparently in an errant place.

Staff Response: *Noted. This will be changed.*

- iv. Non-glazed wall areas (**blank** walls) at the ground level must be enhanced with architectural details, landscaping, and/or landscaped trellises or lattices.
- b. At least two of the following strategies must be used in a manner that reinforces the maximum 25-foot module:
 - i. Change in roof parapet height or shape
 - ii. Change in roof style
 - iii. Change in architectural style
 - iv. Change in building height, minimum 8-foot difference
 - v. Change in frontage type or change in details of Shopfront frontage type if used
 - vi. Use of upper floor projections such as bay windows or balconies.

Commentor: Councilmember Lee Eng/Vice Chair Enander

14. Comment: Is there some logic to having B.1.a, B.1.b, and B.2 reference requirements if facades are greater than 50 feet, but in B.3 the requirements apply if the façade is over 48 feet? Why aren't all the same (either 48 or 50)?

Staff/Consultant Response: *One section refers to the need of a step-back for buildings four stories and above. The other specifically refers to projects immediately adjacent to R-1 properties. In the case of the R-1 design standards, greater protections are given to single-family properties in the R-1 zone. For simplicity's sake the standards can be modified to 50 feet but this is a policy decision for the full City Council.*

Revised 14.24.110 Design Control (R3-1)

- A. Building Placement.** A minimum 85 percent of the building frontage must be built at the minimum setback line. This standard applies to the building frontage only (exclusive of side setbacks).
- B. Building Massing and Articulation.**
1. **Upper-story Step-backs.**
 - a. *Front:* Minimum 5 feet from ground floor façade for fourth story and above for building facades 50 feet or greater in width.
 - b. *Street Side:* Minimum 5 feet from ground floor façade for fourth story and above for building facades 50 feet or greater in width.
 - c. *Interior Side and Rear Abutting an R-1 District:* Minimum 5 feet from ground floor façade for fourth story and above.
 - d. For buildings exceeding the height limit established in the applicable base and overlay zone, the right-of-way-facing facades of the uppermost floor must be embedded in a sloped roof form as allowed by Subsection 5.
 2. **Vertical Articulation.** When a building façade exceeds 50 feet in length along a right of way, it must be separated into primary façade bays no greater than 50 feet and secondary façade bays defined by a recess a minimum of 3 feet deep.



3. **R-1 Adjacencies.**
 - a. Building façade planes abutting an R-1 district may not exceed 48 feet in width.
 - b. When a building façade abutting an R-1 district exceeds 48 feet in width, it must be separated into façade bays no greater than 48 feet by a recess 5 feet wide and 5 feet deep.

Commentor: Councilmember Lee Eng/Vice Chair Enander
Comment: EDITORIAL FIXES

15. Reference errors:

- a. 14.40.150 B.1.a change “Section A.7” to “Section B.7- Edited to refer to Section 14.40.150.B.7.
- b. 14.54.130 A.1.b change “Section A.7” to “Section A.6”- Edited to refer to Section 14.54.130.A.6.

All references throughout the document have been changed to refer to the complete section number.

Commentor: Councilmember Lee Eng/Vice Chair Enander

16. Caption errors

- a. 14.44.130 (CD) A.1.a. required 10 foot upper-story step back. Caption on the diagram says 5 feet-**Noted and corrected.**

Revised 14.44.130 Design Control (CD)

A. Building Massing and Articulation.

1. Upper-story Step-backs.

- a. *Front:* Minimum 10 feet from ground floor façade above 30 feet in height.

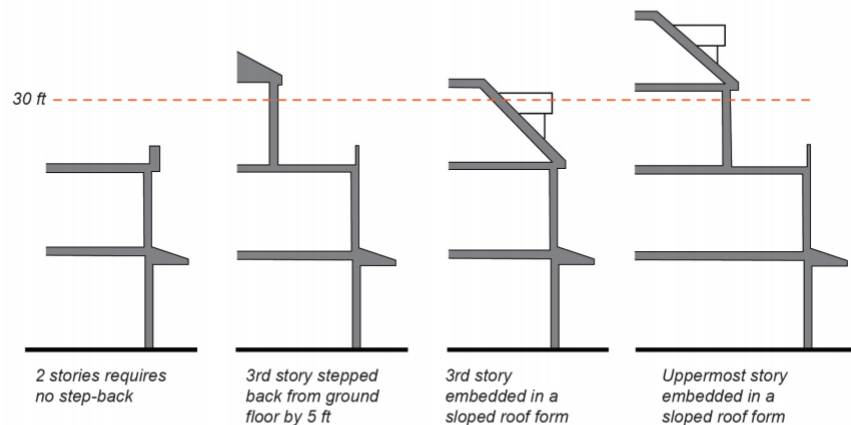

- b. *Street Side:* Minimum 10 feet from ground floor façade above 30 feet in height.
- c. For buildings over three stories in height, the uppermost story must be embedded in a sloped roof form such as a mansard roof or a hipped and/or gabled roof with dormers, as allowed by standards in Section A.6.

- b. 14.52.110 (CD/R3) has the same error- **Noted and corrected**

Revised 14.52.110 Design Control (CD/R3)

A. Building Massing and Articulation.

1. Upper-story Step-backs

- a. *Front:* Minimum 10 feet from ground floor façade above 30 feet in height (commercial or mixed use) or 35 feet (residential only).
- b. *Street Side:* Minimum 10 feet from ground floor façade above 30 feet in height (commercial or mixed use) or 35 feet (residential only).
- c. For buildings over three stories, the uppermost story must be embedded in a sloped roof form such as a mansard roof or a hipped and/or gabled roof with dormers, as allowed by standards in Section A.6.

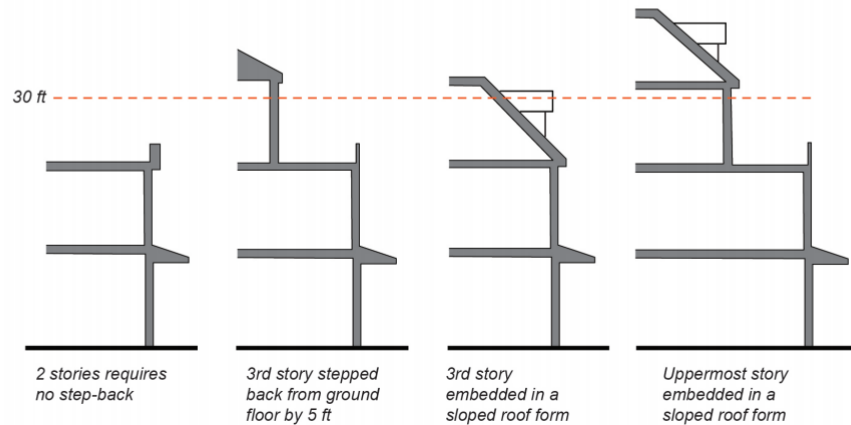

Commentor: Councilmember Lee Eng/Vice Chair Enander

17-Window sill height

- a. CN B.6.b. – why “maximum” sill height? Should be “minimum”?
- b. Also in CRS, CT, CD/R3, CRS/OA

Staff Response: Per the Chief Building Official- the maximum sill height for an ingress/egress window is 44 inches. This verbiage should be changed throughout the entire document. See recommended edits on page 1 of this Memo.

18-CN – C.4.a re: Interior Courtyard

- a. I think there’s a pair of words reversed. It reads “...must be: Partially visible from the street and linked to the street by clear a circulation element.” I think the words “clear” and “a” are reversed. I don’t claim to know what this really means, however.

Staff Response: Agreed. The verbiage needs to be clearer and the phrase “circulation element” needs to be removed and replaced with the words “by a clear accessible path of travel.. Noted and corrected throughout document.

4. **Interior Courtyard.** Interior courtyards must be:
 - a. Partially visible from the street and linked to the street by clear a circulation element.
 - b. Enclosed on at least two sides by buildings
 - c. Open to the sky (arbors and trellises are allowed)
 - d. A minimum width of 20 feet and a minimum area of 400 square feet.

Commentor: Councilmember Lee Eng/Vice Chair Enander

19. CONTENT / POLICY ISSUES

Goal: text and diagrams should be consistent within and between sections and with other height standards. They should be clear enough to avoid potential misinterpretation based on omissions or ambiguities.

- a. The objective height limits for CN, CD, CRS, CD/R3 (commercial/mixed-use) and CRS/OAD are all 30' (35' for all residential in CD/R3). What is the rationale for having the set-backs and roof form requirements referenced to that 30' for CD and CD/R3 but to "stories" for the others? If the assumption is that the third story will always intercept the height limit, why not use the height limit numerically and provide a reference line on all diagrams? Or simply require everything above 2 stories to be set back according to the requirements.

Staff Response: This is the same question as item #3 above. A little more background on this:

The reason we went with stories for CN, CRS and CRS/OAD was based on the directive to "match existing conditions in downtown," which was a directive provided to us by City Council. Our audit of existing conditions in those zones demonstrated that most buildings top out at 2 stories in CN, CRS and CRS/OAD. There are some exceptions, but generally those were the maximum number of stories we observed. So, in order to match those conditions, the standards for those zones were denominated in number of stories, regardless of height.

In the CD and CD/R3, however, there was less consistency in existing conditions. In these districts, the Commission and Council expressed a preference for setbacks required above the base height limit only (which is 30 or 35ft, based on use). As discussed in response to item #3 above, diagrams in previous drafts indicated this intent by showing the stepped-back portion dotted-in, above the base height limit.

The concerns are that specifying a step-back at the 4th story would allow a situation where a height concession permits a tall 3-story building to exceed the base height limit at the street frontage. By specifying that anything above the base height limit must be stepped back, a tall third story above base height limit must still be stepped back (or sloped).

In addition, the revised standard does still allow three stories with no required step-back, provided it does not exceed the base height limit.

CN zone:

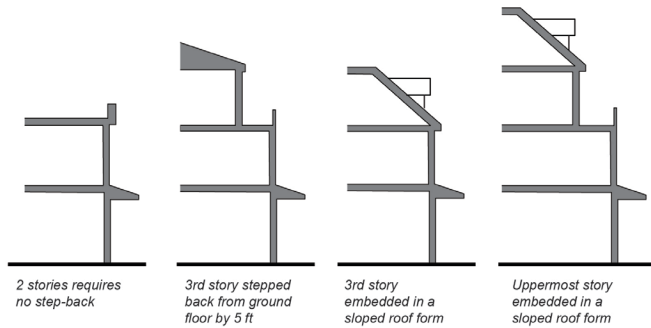

CD zone:

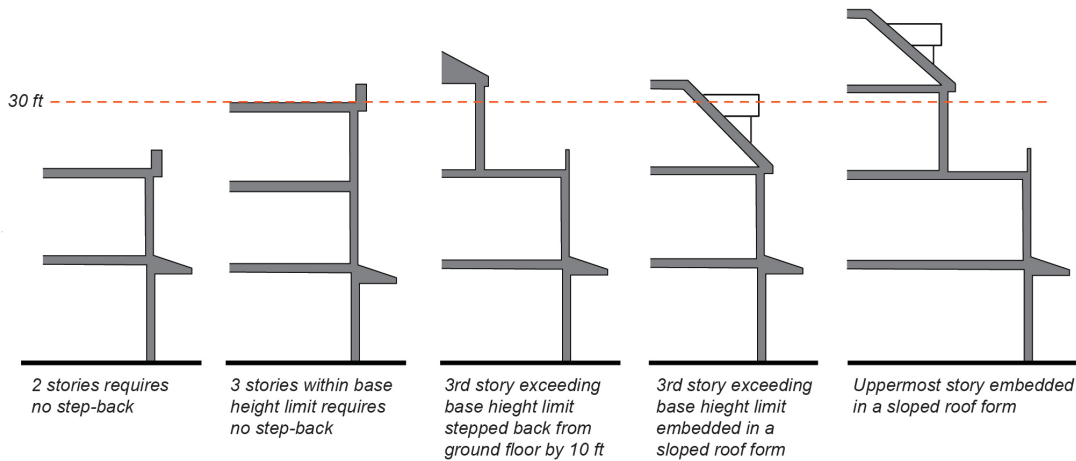

CD/R3 zone:

- b. If we stick with describing height in feet, then as CD/R3 is 30' for commercial or mixed use but 35' for all residential, it would be useful to add a dashed red line at 35' to the diagram

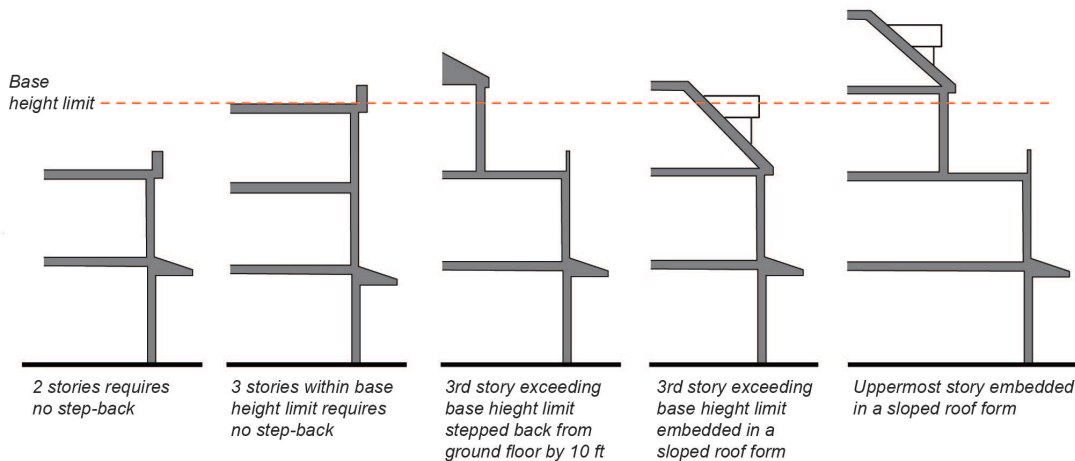

below A.1.c.

Staff Response: Yes, this would be very helpful for staff. Noted; LWC will update CD/R3 diagram dotted line to say “base height limit.”

- c. The CN, CRS, and CRS/OAD all give the option regarding third stories either to setback by a specific minimum number of feet or to embed in the roof form. CD and CD/R3 do NOT give an option to embed the third story in the text (compare the A.1.a for the various zones, except that for CN it is B.1.a.) but DO use the SAME diagrams as the other zones (CN, CRS, CRS/OAD), all of which (3rd from left) are captioned “3rd story embedded in a sloped roof form.” If it is the intention that in CD and CD/R3, the standards would allow a third story to be embedded in a sloped roof form rather than set back, the text should be changed to read as it does for the other zones so as not to present an image that does not match text. Otherwise, the diagrams for CD and CD/R3 should be changed.

Staff Response: Text clarified to match diagrams.

- c. It is unclear in the text for CD and CD/R3 that the requirement to step back the floor that intercepts that height limit requires the entire floor – to the floor plate – to be stepped back. The diagram implies as much, but the text is not explicit.

Staff Response: Agreed. Although the diagram is clear and is understood by staff as to its intent the City Council can determine additional or modified language would be beneficial. Also, note that a building where a floor intercepts a height limit may or may not be considered to exceed the height limit. That is determined per Sec. 14.66.230 - Height limitations—Measurement.

Revised 14.44.130 Design Control (CD)

A. Building Massing and Articulation.

1. Upper-story Step-backs.

- a. *Front:* Minimum 10 feet from ground floor façade above 30 feet in height.

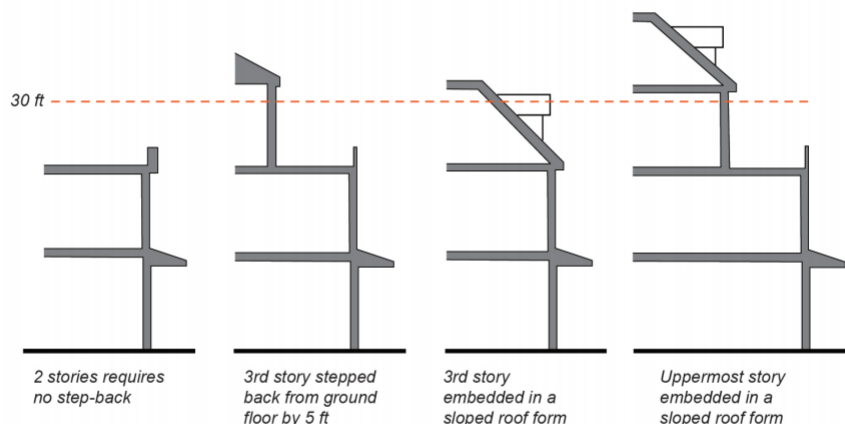

- b. *Street Side:* Minimum 10 feet from ground floor façade above 30 feet in height.
- c. For buildings over three stories in height, the uppermost story must be embedded in a sloped roof form such as a mansard roof or a hipped and/or gabled roof with dormers, as allowed by standards in Section A.6.

- d. It is implied via the diagrams, but not explicitly stated in the text, that any building over 3 stories must have the 3rd story stepped back AND have the “uppermost” story set into one of the specific roof forms. Text should be explicit that both apply. Also, why not say 4th story (if we are sticking with stories?) rather than “uppermost.”

Staff Response: A proposed building above the base height limit must be stepped back. This makes sense from a staff perspective, and it does not feel a modification is needed.

- e. There is nothing in text or diagrams to deal with the possibility of a 5-story building. Are we confident there can't be such? If there is, what setback is required on the 4th story?

Staff Response: Same comment as above. “Uppermost story” may, in fact, refer to a 5th story if height concessions are granted.

20. Additional Edits from Councilmember Lee-Eng

- a. Definitions - we need to make it easy to understand what we clearly mean. (E.g. - sloped roof, what we expect and does 1% slope mean a slope we are willing to accept or the other extreme (89%), both unacceptable) I believe we need to define the acceptable range.

Staff Response: What is considered a mansard, hipped or sloped roof are very well defined in architecture circles so staff are not recommending any change at this time but if the entire City Council wants to add a definition for what kind of sloped roof is acceptable this can be inserted into the definitions section of the code. Additionally, per Sec. 14.66.230 - Height limitations—Measurement: A mansard roof is defined as any roof element with a slope of sixty (60) degrees or greater.

1. **Upper-story Step-backs, Front and Street Side**

- a. Along all frontages except El Camino Real, the third story must be either stepped back a minimum 5 feet from the ground floor façade or embedded in a sloped roof form such as a mansard roof or a hipped and/or gabled roof with dormers, as allowed by standards in Section A.7.

- b. We need to make sure that if we have things come before us on an appeal and can defend ourselves. Clearly describing how we measure and will look at things (e.g. - Finished height and width, and what we mean.)

- c. **Staff Response.** Agreed. The Los Altos Municipal Code's provides the standards used to determine the height of a building. See Section 14.66.230 below for the exact verbiage:

The vertical dimension shall be measured from the average elevation of the finished lot grade at the front, rear, or side of the building, whichever has the greater height, to the highest point of the roof deck of the top story in the case of a flat roof or a mansard roof; and to the average height between the plate and ridge of a gable, hip, or gambrel roof. A mansard roof is defined as any roof element with a slope of sixty (60) degrees or greater.

- d. (pg. 8) - Trellis and landscaping - there should be a method to provide adequate lighting and maintenance.

Staff Response: Adequate light and maintenance of buildings are covered under the Building Code and through the enforcement of the City's Code Enforcement Division.

Objective Standards
Response to Comments
August 11, 2021
Page 21

e. (p. 34) Replace the blank wall restriction.

Staff Response: see the staff response to comment #12 and #13 above

f. (p. 103) Cleanup of the different heights mentioned.

Staff Response: see the staff response to comment #19 above

g. (p. 124) We need to break down each of the elements of Architectural integrity. The elements should be clearly articulated, defined, and made easy to understand to make it somewhat objective.

Staff Response: Agreed. See below.

Architectural Style - We are too vague. (E.g. - for downtown we should be clearly emphasizing the Downtown Building Guidelines)

Staff Response: As noted earlier, there are many elements that went into the development of the objective standards. It is important to note that these are standards that apply to the design of a building, and they do not necessarily emphasize one particular architectural style over another and attempt to do so in a way that includes specifics to numerous elements that in combination define the overall design of a building. The goal is to have a consistent palette of materials and architectural elements across a building. A building based upon the Objective Standards will have “Architectural Integrity,” and will not rely on the somewhat subjective criteria that is used to define the architectural style of a building. City staff are recommending the following the materials standards in each zone:

1. Material palette on all floors above the ground floor, not including floors contained within a sloped roof form, must be consistent.

2. Change in material may occur only at the inside corner of a change in wall plane. Material must wrap around outside corners.

Also, to be consistent in avoiding reference to architectural styles, in the Building Design/Façade design standards in the CD, CRS, CD/R3, CRS/OAD and R3-1 districts, Building “Change in architectural style” has been edited to “change in material palette.”

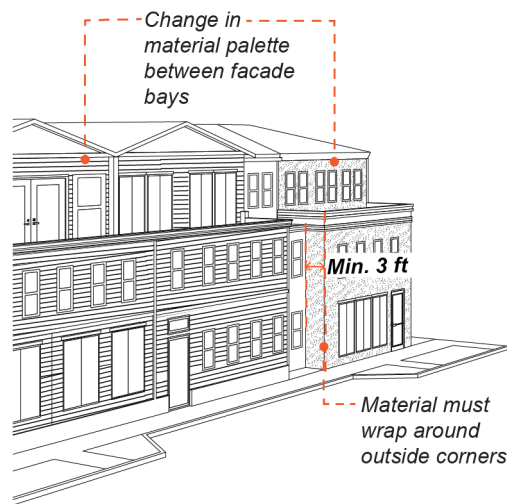

h. (p.78) Underground garages require a warning system and can only be waived if staff determines that due to the specifics of the location that it will not be required.

Staff Response: This is addressed through other City processes and reviews and is not an element appropriate to include in the objective design standards..

Commentor: Mayor Fligor

Comment 21-General comments:

a. Can we label the different diagrams?

Staff Response: Yes. We could label the diagrams Figure 1, Figure 2, and so on for quick reference?

b. Can we add the code in the footer or header of each page so we know what code section we are reviewing? Kept flipping back/forth to see what section I was reviewing.

Staff Response: Added.

-I like the diagrams that have the check for acceptable and X for not acceptable.

Staff Response: Noted.

Commentor: Mayor Fligor

Comment 22-Comment: 2214.40.150 (CN)

22a. B1. Because it says "except El Camino Real" in a couple places, should we add a sentence that points the reader to where the requirements for El Camino are? For eg, please see [_____] for El Camino Requirements.

Staff Response: Besides the standard 25 foot front yard setback, there are no building step-back standards for El Camino Real. Direction from Commission was that this standard should not apply along this roadway.

Revised 14.40.150 Design Control (CN)

- A. Building Placement.** A minimum 75 percent of ground-floor building frontages facing El Camino Real must be built at the minimum setback line. This standard applies to the building frontage only (exclusive of side setbacks).
- B. Building Massing and Articulation.**
 - 1. **Upper-story Step-backs, Front and Street Side**
 - a. Along all frontages except El Camino Real, the third story must be either stepped back a minimum 5 feet from the ground floor façade or embedded in a sloped roof form such as a mansard roof or a hipped and/or gabled roof with dormers, as allowed by standards in Section A.7.
 - b. For buildings over three stories along all frontages except El Camino Real, the uppermost story must be embedded in a sloped roof form.

Comment 22b.

B1a - should be B7 not A7

Staff Response: Yes, this should be modified.

Comment 22c

Staff Response: See staff response below.

Comment 22B1a and 2a: Can we add "For three-story buildings. . ."

Comment 22d

Staff Response: See staff response below.

- 2. **Upper Story Step-backs, Side Interior and Rear where Abutting R-1 District.**

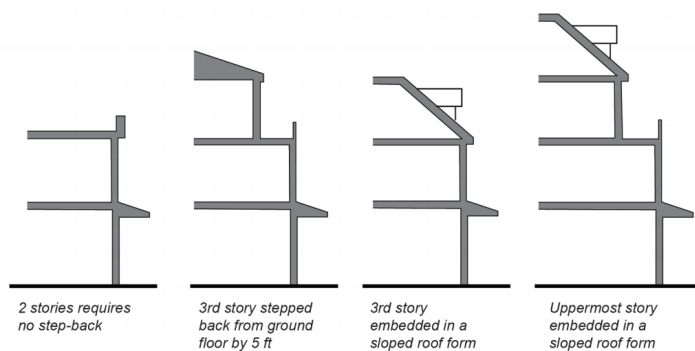

- a. The third story must be either stepped back a minimum 10 feet from ground floor façade or embedded in a sloped roof form.
- b. For buildings over three stories, the uppermost story must be embedded in a sloped roof form.

Staff Response: For comments 22c and 22d, there has been a lot of input on these diagrams from the City Council, staff will raise this a a key discussion point at the meeting so that the City Council. Can provide its collective direction on how best to address this

Comment 22e-

B4b-I think it's better to refer to section B7 instead of just saying roof form

Staff Response: Agreed, references replaced.

Objective Standards
 Response to Comments
 August 11, 2021
 Page 24

- b. The top of each building mass/bay shall be defined by elements spanning the full length of the façade of the mass/bay. Such elements may include a cornice, eave and/or gable(s), or other roof form. These elements shall be consistent with the overall architectural style of the building mass/bay.

Comment 22f-

B6 - The original wording was fine except for the 12 inches requirement. The new language also seems to be saying something different from what's crossed out.

Staff Response: This change was in response to concerns about how the standard was previously framed and a desire to avoid a standard that is based on placement of windows in other (neighboring) projects. See comment 1 on page 1 of this memo for further detail.

Comment 22g-B7 - Comment --Interesting re Fremont Avenue

Staff Response: The Mayor commented “interesting.” Please indicate if you would like City staff to follow up on a specific edit or comment.

7. **Roofline and Roof Design.**

- a. Roof designs shall be limited to:
- i. Hipped
 - ii. Gable
 - iii. Shed
 - iv. Dormer
 - v. Parapet
 - (a) Not allowed on frontages facing Fremont Avenue.
 - (b) When used on the first or second floor, a parapet longer than 25 feet in length must include at least one but not more than two of the following design elements to break up the length of the parapet:
 - (1) Steps
 - (2) Curves
 - (3) Angled surfaces

Comment 22h-

C2c- Comment/Question-why deleted?

Staff Response: Re-inserted - . “Ground floor residential units facing a street must provide individual entries along the street frontage” and is now, applied to the CN, CD, CT, CD/R3, and R3-1 districts.

Comment 22i

E1- Are there other acceptable types of siding materials? It says all siding must be wood, composite wood or cement fiberboard, but then excludes vinyl and aluminum. Its either we don't need to exclude vinyl/aluminum if only wood, etc are allowed, or we state everything is allowed except vinyl

Objective Standards
Response to Comments
August 11, 2021
Page 25

and aluminum.

Staff Response: This is to emphasize that vinyl and aluminum are not allowed/permitted. Feedback from the Planning Commission during its review of the objective standards indicated a desire to make this explicit and the proposed language reflects their recommendation.

E. Building Materials.

1. Primary shall mean 50 percent or more of a façade surface area. The following primary cladding materials are allowed:
 - a. Stucco (minimum 2-coat stucco; synthetic stucco or EIFS not allowed)
 - b. Siding (lap, vertical, panelized, or shingle)
 - i. All siding shall be wood, composite wood, or cement fiberboard.
 - ii. Wood siding shall be painted or stained.
 - iii. Vinyl and aluminum not permitted.
 - c. Stone
 - d. Brick

Comment 22(j) - E- why was this section on open space deleted? Can we reinstate?

Staff Response: The standard stated “Where any required front, rear, or side yard setback is 10 feet or greater, on-site ground-level open space shall be provided within the setback. The comment points out that this was removed from the CD district. This is because in the CD district the only setback that is 10 feet or greater is the rear yard setback; thus, it seemed appropriate, given the direction, that this language only apply to the rear setback.

Commentor: Mayor Fligor

Comment 23.

14.48.130 (CRS)

23a. B4- Does it matter if its nonresidential vs residential for the floor-to-floor ceiling height?

Objective Standards
Response to Comments
August 11, 2021
Page 26

elements are exempted.

- g. **Ground Floor Floor-to-Ceiling Height.** Minimum 24 inches taller than typical upper floor floor-to-ceiling height.

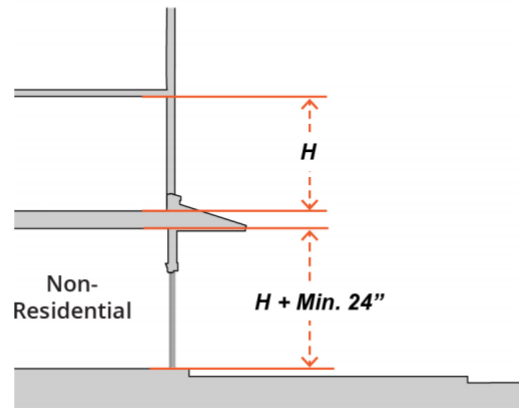

Staff Response: in the CRS zoning district, residential is only allowed above the ground floor in this zone so the standards are for nonresidential uses.⁷

⁷ See 14.48.040(e)- Conditional uses and structures (CRS).

E. Housing located above the ground floor;

Comment 23b-F5- assume those separate sections cover fast growing, etc

5. See Sections 14.66.180 (Maintenance of Landscaped Areas) and 14.70.070 (Landscaped Strips) for additional landscaping standards.

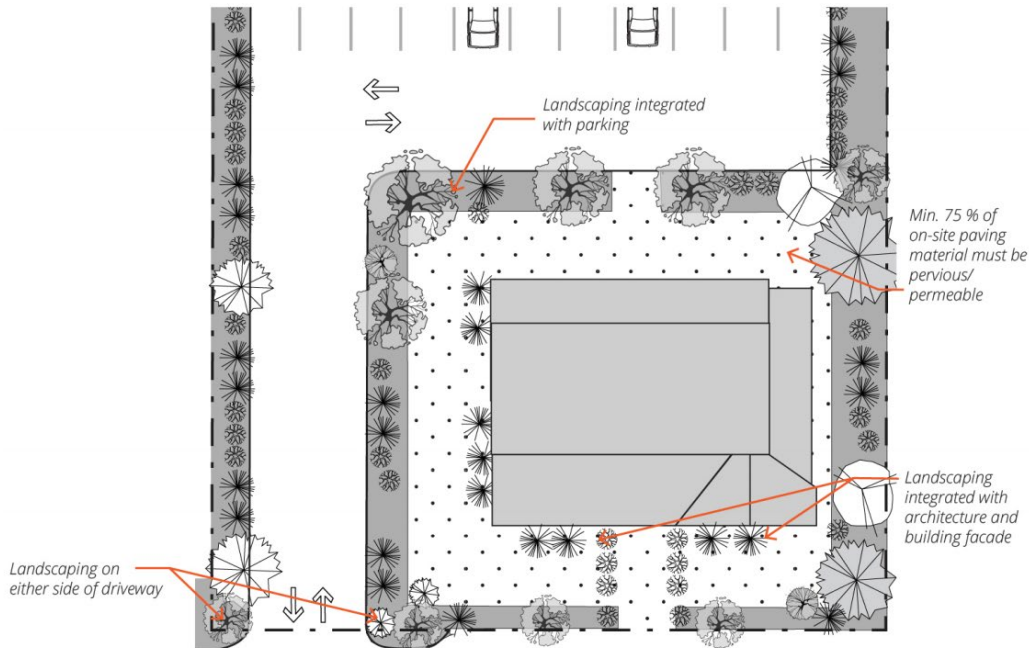

Staff Response: Section 14.66.180 and 14.70.070 adequately protect landscape strips within projects. The language is expansive but if the Council is concerned the words “*or as a condition of approval*” and “*fast growing*” can be added to the following sentence “a landscape strip or other landscaped areas provided in compliance with district regulations or as a condition of a use permit or a development project shall be planted with fast growing fast growing” material.....”

14.66.180 - Maintenance of landscaped areas- A landscaped strip or other landscaped area provided in compliance with district regulations or as a condition of a use permit shall be planted with materials suitable for screening or ornamenting the site, whichever is appropriate, and plant materials shall be replaced as needed to screen or ornament the site. Landscaped strips and other landscaped areas shall be watered, weeded, pruned, fertilized, sprayed, or otherwise maintained as deemed necessary by the building inspector.

14.70.070 - Landscaped strips- A landscaped strip not less than five feet in depth shall be planted and permanently maintained throughout the length of all property lines adjoining residential sites and throughout the length of all property lines on adjoining streets, as approved by the architecture and site control committee.

Commentor: Mayor Fligor

Comment 24.

- a. 14.50.170 (CT)

H- Worded differently from a previous section that used the word “Lined”. Intentional?

Staff Response: Yes; the text and definitions were both edited for clarity based on feedback received.

CRS

G. Parking Design and Access.

1. Where structured parking is provided, the parking area must be either:
 - a. "Lined" with ground-floor non-residential uses at least 30 feet deep as measured from the front façade; or

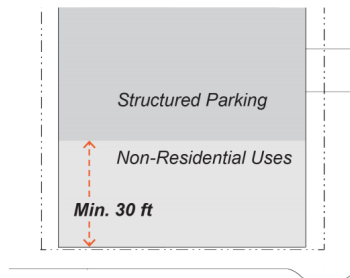

CT

H. Parking Design and Access.

1. Where structured parking is provided, the parking area must be either:
 - a. Located behind ground-floor non-residential uses at least 30 feet deep as measured from the front façade; or

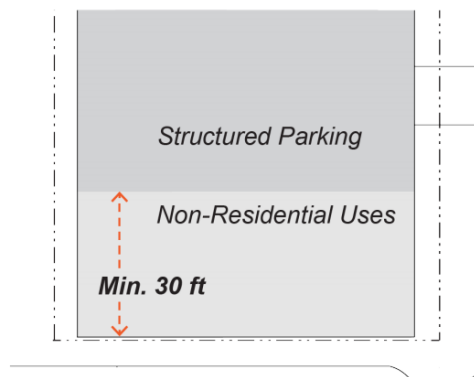

Staff Response: Yes, the verbiage between the CRS zone and the CT zone are different. Edited to be consistent.

Commentor: Mayor

Objective Standards
 Response to Comments
 August 11, 2021
 Page 29

Comment 25-14.52.110 (CD/R3)-B2f - I thought we talked about changing it to require 2 or more standards for the street facing entries.

Staff Response: Agreed. Text edited to say “two or more.”

- f. *Street-facing Entries to Upper Floors.* Street-facing entries to upper floors shall be equal in quality and detail to storefronts. This standard may be satisfied through one or more of the following:
- i. Dedicated awning, canopy, or other roof element
 - ii. Stairs with a single color applied to treads and a contrasting color or pattern applied to risers.
 - iii. Dedicated light fixture(s)
 - iv. Decorative street address numbers or tiles
 - v. Plaque signs for upper-floor business tenants

Commentor: May

26. Comments

14.54.130 (CRS/OAD)

-A1a and b - Should it be A6?-

Staff Response: Edited

-B1 - Should it be 50 and not 25-foot module?

Staff Response: This is a 25 module per existing Code Sec. 14.54.130.B.2 and Downtown Design Guidelines Sec. 3.2.1.a and 3.2.8.

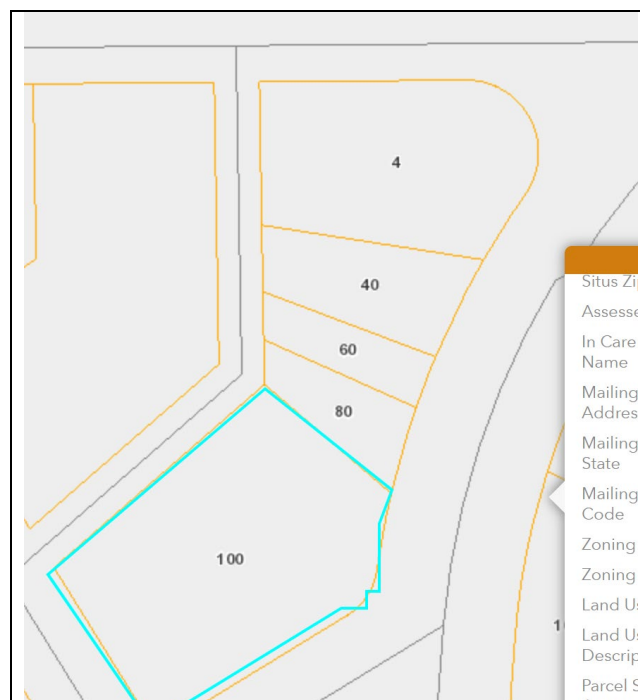

Objective Standards
Response to Comments
August 11, 2021
Page 30

Staff Response: The zoning district is CRS/OAD and the original direction from the City Council was to keep the development patterns consistent with the downtown. Most of the downtown has 25 foot parcels so 25 feet is what would be consistent with what is currently in place.

B1 - Change second "a" to "b"

Staff Response: Edited.

-E - should be gateway, not gateways-

Staff Response: Edited.